

Operating Instruction

BA 200 GB - Edition 06/11

Title	Page
EC Declaration of Conformity acc. to Low Voltage Directive 2006/95/EC	2
Safety information for the operation of geared motors	3-4
Geared motors with three phase cage rotors	5-12
Lubrication quantity series BG	13
Lubrication quantity for BG20-01R	14
Lubrication quantity series BF	15
Lubrication quantity series BK	16
Lubrication quantity series BS	17
Lubrication quantity series BM	18
Lubrication quantity for gear design with free running input shaft	19
Lubrication quantity coupling lantern	20
Lubrication quantity for pre-stage	21
Lubrication quantity for intermediate gear	22
Spring-loaded DC brakes Models E003B and E004B	23-27
Spring-loaded DC brakes Models ES(X)010A ... ES(X)250A, ZS(X)300A, ZS(X)500A	28-43
Electrical brake connection	44-47
Brake connection: special rectifier ESG 1.460A	48-49
Brake connection: DC voltage supply	50
Brake connection: special rectifier MSG...I	51-52
Brake connection: special rectifier MSG...U	53
Brake connection: standard rectifier SG 3.575B	54-57
Rectifier on motor terminal block or cage clamp	58
Manual release spring loaded DC brake Models E003B und E004B	59
Manual release spring loaded DC brake Models ES(X)010A ... ES(X)250A, ZS(X)300A, ZS(X)500A	60-62
Gear units designed with torque arms and rubber buffers for series BF	63
Gear units designed with torque arms and rubber buffers for series BK	64
Gear units designed with torque arms and rubber buffers for series BS	65
Geared motors with backstop	66
Assembly of standard motor with C-Adapter (IEC and NEMA)	67
Assembly and disassembly of the shrink-disc	68
Information on the storage of geared motors with cage rotors	69-70



These documents must be kept with the unit.

Further documentation can be found under www.bauergears.com

EÜ vastavusdeklaratsioon

vastavalt madalpingedirektiivile 2006/95/EÜ
kõigi voluliikide ja ülekandemudelitega mootorreduktoritele

B 010.0800-01 Seis: 11/06
Fail: KonfErkl_NSR_B010_0800_01_EE.doc

Bauer Gear Motor GmbH
Postfach 10 02 08
D-73726 Esslingen
Eberhard-Bauer-Str. 36-60
D-73734 Esslingen
Telefon: (0711) 35 18 0
Telefax: (0711) 35 18 381
e-mail: info@bauergears.com
Homepage: www.bauergears.com

Bauer Gear Motor GmbH
Eberhard-Bauer-Str. 36-60, D-73734 Esslingen

deklareerib käesolevaga oma ainuvastutusel järgmiste toodete vastavust:

Elektrimootorid seeriatest

D..04, D..05, D..06, D..07; D..08, D..09, D..11, D..13, D..16, D..18, D..20, D..22, D..25, D..28
E..04, E..05, E..06, E..07, E..08, E..09
S..06, S..08, S..09, S..11, S..13

koos:

ülekannetega seeriatest:

silinderülekanded BG.., lameülekanne BF.., koonushammasülekanne BK.., tiguülekanne BS.., elektriliste rippteede ülekanne BM..

vastavad kehtivate Euroopa direktiivide nõuetele
madalpingedirektiiv - 2006/95/EÜ
mis puudutab teatud pingevahemikus kasutatavaid elektriseadmeid

mis on tõendatud järgmiste harmonseeritud normide järgimisega:

Pöörlevad elektrimasinad

EN 60034-1:2004
EN 60034-5:2001
EN 60034-6:1993
EN 60034-8:2002
EN 60034-9:2005
EN 60 529:1991

Osa 1: Nimitingimused ja jõudlus
Osa 5: Kaitseklassid (IP-kood)
Osa 6: Jahutusmeetodid (IC-kood)
Osa 8: Klemmide märgistused ja pöörlemise suund
Osa 9: Mürapiirid
Korpuse kaitseklass (IP-kood)

Märkused:

Kaasasoleva dokumentatsioonid (nt kasutusjuhend) ohutusjuhisei tuleb järgida.

Esslingen, esmase väljastamise kuupäev 01.07.1999

Bauer Gear Motor GmbH



i.V. Hanel
(Leiter IM)



i.V. Dipl.-Ing. Eiffler
(Leiter EE)

See deklaratsioon ei sisalda omaduste tagamist tootevastutuse tähenduses. Tootja ja dokumentatsiooni volitatud koostaja on ettevõtte Bauer Gear Motor GmbH

THE GEAR MOTOR SPECIALIST

An Altra Industrial Motion Company

Erfüllungsort und Gerichtsstand: 73734 Esslingen
Sitz: Esslingen-Neckar
Registergericht: Amtsgericht Stuttgart HRB 736269
Geschäftsführer: Karl-Peter Simon
USt-IdNr.: DE 276650470 - Steuer Nr. 59330/13048

Bankverbindungen:
Kreissparkasse Esslingen (BLZ 611 500 20) Nr. 101551300
BIC/SWIFT: ESSLDE66 IBAN: DE85 6115 0020 0101 5513 00
Commerzbank Esslingen (BLZ 611 400 71) Nr. 700408800
BIC/SWIFT: COBADEFF611 IBAN: DE21 6114 0071 0700 4088 00

Safety information for the operation of geared motors

(in accordance with the Low Voltage Directive 2006/95/EC)

General

This safety information applies in addition to the relevant product-specific operating instructions and for safety reasons must be taken into particular consideration in every case.

This safety information is intended to protect persons and objects from injury and hazards which can arise from improper use, incorrect operation, inadequate maintenance or other incorrect handling of electric drive units in industrial installations. Low-voltage machines have rotating parts and may have parts that are live, even when the machine is at rest, and surfaces that may become hot in operation. Warning signs and information signs on the machine are to be observed without exception. Details may be found in our detailed operating instructions. They are provided with the machine when it is supplied and can be requested separately as required by stating the motor model.

1 Personnel

All necessary work on electric drive units, in particular also planning work, transport, assembly, installation, commissioning, maintenance, repair, may only be performed by adequately qualified personnel (e.g. electrical engineers as specified in draft EN 50 110-1/DIN VDE 0105), who have the operating instructions provided and other product documentation available during any corresponding work and who are obliged to abide by the instructions contained therein. This work is to be monitored by a specialist supervisor. Qualified personnel are persons who are authorised due to training, experience and instruction as well as their knowledge of relevant standards, rules, accident prevention regulations and operating conditions by the person responsible for the safety of the installation to perform the activities required in each case and who are able to recognise and avoid possible hazard.

Knowledge of first-aid measures and of the available lifesaving equipment is also required.

Non-qualified personnel shall be forbidden to work on the geared motors.

2 Intended use taking into account the relevant technical regulations

These machines are intended for commercial installations, unless otherwise expressly agreed. They comply with the standards of the series EN 60034/DIN VDE 0530. Use in a potentially explosive atmosphere is forbidden, if not expressly intended for this purpose (refer to additional information). If in a special case --use in non-commercial installations-- Increased safety precautions are required (e.g. protection against access by children's fingers), these conditions are to be ensured when setting up the installation. The machines are designed for ambient temperatures between -20°C to $+40^{\circ}\text{C}$ as well as for installation heights up to 1000 m above sea level. Any deviations found on the rating plate must be taken into consideration. The conditions at the place of work must correspond to all rating plate data.

Low-voltage machines are components for installation in machines in the sense of the Machinery Directive 2006/42/EC.

It is forbidden to use the machine until conformity of the final product with this directive is established (consult EN 60204-01).

3 Transportation, storage

When the electric drive units are being transported, the eye bolts -- where provided in the design-- must be firmly tightened down their bearing surface. They may be used only for transporting the drive unit and not for lifting both the drive unit and the driven machine. Damage sustained after delivery must be reported to the haulage company immediately. Commissioning may have to be suspended.

If drive units are to be stored, ensure a dry, dust free and low vibration (veff < 0,2 mm/s) environment (damage sustained during storage). The life of the lubricants and seals is reduced with longer storage times.

There is a risk of fracture at very low temperatures (under approximately -20°C). If the transport eye bolts are replaced, drop forged eye bolts as specified in DIN 580 are to be used.

4 Mounting arrangement, assembly

The drive unit is to be fastened by its flange or foot if an IM.. mounting arrangement is intended. Gear units with hollow shafts are to be attached on the driven shaft using the means provided.

Caution! Depending on the reduction ratio, geared motors develop substantially higher torques and forces than high-speed motors of similar power.

Mounts, substructure and torque restraint are to be rated for the high forces to be anticipated during operation and secured sufficiently against loosening. The output shaft(s) and any second motor shaft extension present as well as the transmission elements mounted on it (couplings, chain wheels etc.) are to be covered so that they cannot be touched.

5 Connection

All work shall only be carried out by qualified technical personnel on a stationary machine which has been protected against re-starting. This applies also to auxiliary circuits (e.g. stationary heating). Remove any transportation blocks before start-up.

Check to ensure safe isolation from the supply!

The terminal box may only be opened once it has been ensured that the power is switched off. The information on voltage and frequency on the rating plate must correspond with the mains voltage under observance of the terminal circuit. Exceeding the tolerances as in EN 60034 / DIN VDE 0530, i.e. voltages $\pm 5\%$, frequency $\pm 2\%$, cam form, symmetry, increases heating and reduces service life.

Accompanying connection diagrams, particularly for special equipment (e.g. pole-changing, thermistor protection etc.), are to be observed. Type and cross-section of the main conductors as well the protective conductors and any potential equalization which may become necessary must correspond to the general and local installation regulations. With switching duty, the starting current is to be taken into account.

The drive unit is to be protected against overloading and in dangerous situations against automatic restarting due to inadvertent starting.

The terminal box is to be locked again to protect against contact with live components.

6 Commissioning

Before commissioning, protective films are to be removed, the mechanical connection to the driven machine disconnected as far as possible and the direction of rotation examined in the no-load state. Feather keys are to be removed or secured in such a way that they cannot be ejected as this is done. Ensure that the current draw in the loaded condition does not exceed the rated current indicated on the rating plate for any length of time. Observe the drive unit after first commissioning for at least one hour for any unusual heat or noise.

7 Operation

With certain layouts (e.g. unventilated machines), relatively high temperatures can occur on the motor frame, which are however within the limits specified in the standard. If these drive units are located in a place where they are subject to intensive contact, measures must be taken by the installer or operator to provide protective shielding.

8 Spring-loaded brakes

Spring-loaded brakes are safety brakes which continue to work in the event of power failure or usual wear. If a manual release bracket is provided, it is to be removed when operating. Since other components could also fail, suitable safety precautions are to be taken to avoid any injury to persons or damage to objects caused by un-braked operation.

9 Maintenance

In order to prevent breakdowns, danger and damage, the drive units must be examined at regular intervals depending on the operating conditions. The lubrication intervals for bearings and gear units specified in the respective operating instructions are to be observed. Worn or damaged parts are to be replaced using original spare parts or standard parts. In the event of heavy dust accumulation, clean airways regularly. For all inspection and maintenance work, observe Section 5 and the information provided in the detailed operating instructions.

10 Operating instructions

For reasons of clarity, the operating instructions and safety information do not contain all information relating to all geared motors types and cannot take into account every conceivable case of installation, operation or maintenance. The information is essentially limited to that which is required for qualified personnel in normal working situations. Any unclear points can be clarified by contacting Bauer.

11 Faults

Changes in relation to normal operation, such as higher temperatures, vibrations, noises etc. tend to indicate that the function is impaired. To avoid faults which could lead directly or indirectly to injury to persons or damage to property, the maintenance staff responsible must be informed. If in any doubt, the geared motors are to be switched off immediately.

12 Electromagnetic compatibility

The operation of the low-voltage machine in its intended application must meet the protection requirements of the EMC (electromagnetic compatibility) Directive 2004/108/EC.

Correct installation (e.g. screened cables) is the responsibility of the system's installers. Precise information can be taken from the operation instructions. For systems with frequency inverters and rectifiers, the manufacturer's electromagnetic compatibility information is also to be taken into consideration. The electromagnetic compatibility directive in accordance with EN 61000-6-2 and EN 61000-6-4 is complied with given proper use and installation of BAUER geared motors. This is also true in combination with frequency inverters and rectifiers. The additional information provided in the operation instructions is to be taken into consideration when using the motors in the residential, commercial and trade sectors, as well as in small businesses in accordance with EN 61000-6-1 and EN 61000-6-3.

13 Warranty and liability

The warranty obligations of Bauer arise out of the relevant supply contract, which is neither expanded nor restricted by this safety information or other instructions.

This safety information is to be kept in a safe place.

Geared motors with three phase cage rotors

General Notes

The operating instructions are an intergral element of the product and must be available in a readable form at all times. Employees responsible for the plant and operations together with all who have to work with the unit must have read and understood the operating instructions completely.

Disclaimer

Observation of the operating instructions is a prerequisite for the safe use and the attainability of the product performance of the geared motor.

Bauer does not accept liability for personal, material or economical damages caused by non-observation of the operating instructions. Liability for defects are excluded in such cases.

Geared motors in degree of protection IP65

(Motor models D/E06... to D.28...) complying with EN 60529 and IEC 34-5/529 are totally enclosed and dust-tight as well as hose proof.

For outdoor installation, the geared motor must be coated with several layers of durable paint to protect against corrosion. The condition of the paint must be checked and repaired at regular intervals, depending on ambient influences. The paint finish must be compatible with the other components. Paints with a synthetic resin base have proved well suited to this purpose.

Geared motors in degree of protection IP54

(Motor models D/E04... and D/E05...) complying with EN 60034, part 5 and IEC 34-5 are protected against dust and occasional splashing water. Installation outdoors or in wet areas is not permissible without special protective measures.

Mounting arrangement

It is recommended that drinking water, food, textiles etc. beneath the geared motor be covered.

The drive unit should be installed as free from vibration as possible.

Special instructions are to be observed in installation locations with abnormal operating conditions (e.g. prolonged exposure to dripping water, high ambient temperatures above 40°C, explosion hazards). The fresh air intake must not be restricted by unsuitable installation or by fouling.

Flexible couplings with zero play, if possible, are recommended for direct power transmission from the gear unit to the driven machine and commercially available slip clutches are recommended if there is a risk of blocking.

Care must be taken when fitting transmission elements onto the output shaft of the gear unit, which is finished to ISO k 6 or m 6, and the tapped end hole intended for this purpose according to DIN 332 should be used if possible. Warming the machine part to be fitted onto the shaft to approximately 100 °C has proved to be advantageous. The bore must be dimensioned in accordance with following table and must thus exhibit the following tolerances:

Nominal size of bore (in mm)	k 6 or m 6 output shaft Bore H7 with tolerances (in $^1/1000$ mm)
over 6 to 10	0 to + 15
over 10 to 18	0 to + 18
over 18 to 30	0 to + 21
over 30 to 50	0 to + 25
over 50 to 80	0 to + 30
over 80 to 120	0 to + 40

Where the gear units have a hollow shaft and keyway for high profile feather keys as specified in DIN 6885, Part 1 and hollow shaft for shrink-disc connection, the shafts intended to form the counterpart must be dimensioned to ISO h 6. They must, therefore, exhibit the following tolerances:

Shaft diameter (in mm)	Nominal allowance (in $^1/1000$] mm)
over 18 to 30	0 to - 13
over 30 to 50	0 to - 16
over 50 to 80	0 to - 19
over 80 to 120	0 to - 22
over 120 to 140	0 to - 25

In all cases, particular care shall be taken to ensure that any burring, swarf etc. is carefully removed before assembly. The keyways should be lightly greased to prevent seizing. Hollow shafts to be fitted with shrink-disc connections must not be greased. The following installation instructions are to be noted here.

The eye bolt is to be retightened firmly if it has worked loose during transportation.

Electrical connection

When connecting the motor, take note of the rating plate information and the connection diagram as well as the relevant safety regulations and rules for the prevention of accidents.

Unless a special design is concerned, the rating data refer to $\pm 5\%$ voltage tolerance, -20 to 40°C ambient temperature and altitudes up to 1000 m above sea level.

Small motors can be connected directly (the regulations of the local electricity supply companies are to be observed). The permissible switching frequency depends on the design of the motors, the load torque and the mass moment of inertia.

The direction of rotation of single phase motors may generally only be changed after the motor has stopped and in accordance with the following diagram:

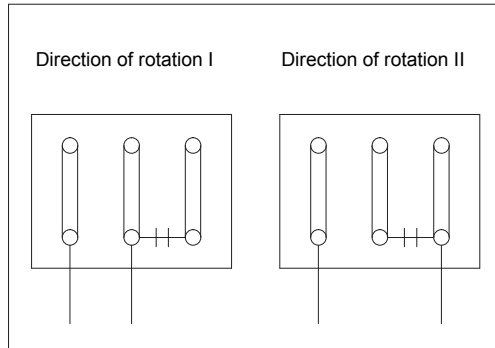

Unless otherwise stated, the three phase motor is connected for the higher of the two rated voltages specified. The motor may have to be connected from star to delta at the terminal board, if necessary, to ensure that it complies with the mains voltage.

Specially designed motors (e.g. for two rated voltages in the ratio 1:2 or with pole-changing windings) are to be connected in accordance with the relevant circuit diagram.

Two mains leads must be swapped in the event of incorrect direction of rotation. When closing the terminal box, particular attention must be given to obtaining a perfect seal. With motors in sizes D/E 04 to D/E 09 with moulded terminal boxes, two connection openings each on side A and C are possible.

The cable entry openings required depending on the installation position should carefully pierced with a suitable tool. Take care not to damage the terminal board.

Two lock nuts and seals are provided in the terminal box for the cable glands (metric). Plugs must be screwed into unused cable entry holes.

The maximum spanner opening for the cable glands of the D04 is 24 mm and of the D05 to D09 is 29 mm.

To guarantee electromagnetic compatibility (EMC) as defined in EMC Directive 2004/108/EC, all signal lines must use shielded cables. The cable sheath is to be earthed at both ends. The frequency inverter operating instructions will indicate whether a shielded cable is necessary for the motor supply line. A shielded motor cable is not required when connecting to the low-voltage network or to a frequency inverter with an output filter. Signal cables and power cables should not be laid parallel over long distances.

Overload protection

A motor protection switch must be used to protect the winding against overloading and against the consequences of operating on only 2 mains leads (e.g. when only one fuse blows or in the event of a wire breakage)

Example	Motor winding for 230/400 V; Rated currents	5.7/3.3 A
	Setting of the motor protection switch at Connection for 230 V (delta):	5.7 A
	Connection for 400 V (star):	3.3 A

The overcurrent relay of the motor protection switch is to be set to the correct rated current intensity for the rated voltage concerned (see rating plate). Take note of the relevant circuit diagram for motors with thermally activated winding protection (e.g. thermostats or thermistors).

Automatic restarting after the winding has cooled must be avoided in most applications.

The output of the motors is normally adequately rated, particularly in connection with four and multistage gear units. The rated current does not represent a measure of gear unit utilization in these cases and cannot be used as overload protection for the gear unit. In some cases, the way in which the driven machine is loaded can exclude any overloading as a matter of course. In other cases it is prudent to protect the gear unit by mechanical means (e.g. slip clutch, sliding hub etc.). The maximum permissible limit torque M_2 in continuous running duty specified on the rating plate is decisive here.

Lubricant changes

The gear units are supplied with lubricant ready for operation.

In normal operating conditions and with a lubricant temperature of approximately 80° C, the oil should be replaced after approximately 15000 operating hours when using CLP 220, or after 25000 operating hours when using PGLP 220/PGLP 460. The lubrication interval must be reduced at higher temperatures (halve it for each 10 K increase in the lubricant temperature).

The lubricant must be changed after 2 or 3 years at the latest whatever the operating hours.

The medium and larger gear units have filling plugs and drain plugs. In the standard designs, these make it possible to change the lubricant without disassembly.

With smaller gear units, the interior is accessed by unscrewing the connecting bolts. Alignment pins and centring secure the precise assembly.

Worm-gear units are sliding gear units whose tooth flanks, contrary to rolled gear units, only become smooth once run in. They should therefore initially be run in under partial loading (about $\frac{2}{3}$ of the rated load) until the full load capacity of the flanks and the optimal efficiency is achieved. After approximately 200 operating hours, the lubricant should be changed and the gear unit enclosure thoroughly flushed, so that the minimal, but inevitable amount of material removed by smoothing abrasion is cleared.

It is also necessary to flush the gear unit enclosure if the lubricant grade or lubricant type is changed.

If the motor is only used briefly it is sufficient to drain off the original oil and use the original lubricant type to refill the maximum possible amount for the gear unit as defined in the lubricant volume table. Then operate the drive unit briefly under no load, drain this oil off again and refill with the new lubricant as defined on the rating plate. In special cases, refill up to the oil level mark. If necessary, drain off the original lubricant and flush out the gear unit with petroleum until all traces have been washed out. Then perform the procedure described above for short-term operation twice before filling with the specified volume of new lubricant in accordance with the rating plate, in special cases up to the oil level mark.

It is advisable to inspect and if necessary replace the wear parts (bearings and seals) when changing the lubricant.

Lubricant grade

Oils CLP 220, PGLP 220 and PGLP 460 complying with DIN 51502 and DIN 51517 are suitable for lubricating the gear unit, or in special cases use soft flow grease GLP 00f with good EP properties.









The lubricant must permit low-friction, virtually wear-free continuous operation. The damage load level on the FZG test as specified in DIN 51354 shall be in excess of load level 12, and the specific wear below 0.27 mg/kWh. The lubricant should not foam, should protect against corrosion and should not attack the interior paint, the rolling contact bearings, gearwheels and seals.

Lubricants of different types may not be mixed, as otherwise the lubrication characteristics may be impaired. A long service life is only ensured by the use of a lubricant listed below or which is demonstrably equivalent.

Storage

Should geared motors need to be stored for a longer period of time before installation, please observe the chapter „Information on the storage of geared motors with cage rotors“

Wear-protecting EP gear lubricant oils as listed in the lubricant table below have proved particularly suitable.

Lubricant manufacturer	Lubricant type				
	Mineral oil	Synthetic oil			USDA H1 oil
	ISO VG 220	ISO VG 68	ISO VG 220	ISO VG 460	ISO VG 220
	Standard oil for gear units of type series BF06-BF90 BG04-BG100 BK60-BK90	Low temperature oil for gear units of type series BF06-BF90 BG04-BG100 BK60-BK90 BS02-BS40	Standard oil for gear units of type series BS02-BS10 BK06-BK10 High temperature oil for gear units of type series BS02-BS10 BK06-BK10 BF06-BF90 BG04-BG100 BK60-BK90	Standard oil for gear units of type series BS20-BS40 BK20-BK50 High temperature oil for gear units of type series	Foodstuffs industry oil of type series BF06-BF90 BG04-BG100 BK06-BK90 BS02-BS40
AGIP 	BLASIA 220				
ARAL	DEGOL BMB220 DEGOL BG220		DEGOL GS220	DEGOL GS460	
BECHER RHUS 	STAROIL SMO220				
BP 	ENERGOL GR-XP220		ENERSYN SG-XP 220	ENERSYN SG-XP 460	
CASTROL 	ALPHA SP 220 ALPHA BMB 220 OPTIGEAR BM 220 TRIBOL 1100/220		ALPHASYN PG 220 TRIBOL 800/220 ALPHASYN GS 220	ALPHASYN PG 460 TRIBOL 800/460 ALPHASYN 460	CASTROL OPTILEB GT 220 CASTOL TRIBOL FOODPROOF 1800/220
ESSO	see MOBIL				
FUCHS 	RENOLIN CLP 220 RENOLIN CLPF 220 SUPER	RENOLIN PG 68	RENOLIN PG 220	RENOLIN PG 460	
KLÜBER 	KLÜBEROIL GEM 1-220 N	KLÜBERSYNTH GH6-80	KLÜBERSYNTH GH6-220	KLÜBERSYNTH GH6-460	KLÜBEROIL 4UH1-220N KLÜBERSYNTH UH1 6-220
MOBIL 	MOBILGEAR 600 XP 220 MOBILUBE HD PLUS 80W-90		GLYGOYLE 220 GLYGOYLE 30	GLYGOYLE 460	
OEST 	Gearol C-LP 220				
OPTIMOL	OPTIGEAR 220		OPTIFLEX A 220	OPTIFLEX A 460	OPTILEB GT 220
SHELL	OMALA S2 G220 FALCON CLP 220		OMALA S4 WE 220	OMALA S4 WE 460	CASSIDA FLUID GL 220
TEXACO	GEARTEX EP-A SAE 85W-90				
TOTAL	CARTER EP 220				NEVASTANE SL220
WINTERSHALL	SRS ERSOLAN 220				



ATTENTION!

Synthetic gear oils with a polyglycol base (e.g. PGLP etc) must be kept separate from mineral oils and disposed of as special waste.

As long as the ambient temperature does not fall below -10°C , ISO viscosity grade VG 220 (SAE 90) is recommended in accordance with the international definition of viscosity grades at 40°C in accordance with ISO 3448 and DIN 51519, and AGMA 5 EP in North America.

For lower ambient temperatures, oils of a lower nominal viscosity, with correspondingly better starting characteristics should be used, such as PGLP with a nominal viscosity of VG 68 (SAE 80) or AGMA 2 EP. These grades may also be required at temperatures around the freezing point if the drive unit's breakaway torque has been reduced with a view to achieving soft starting or if the motor has a relatively low power output.

Lubricant volume

The recommended lubricant quantity for the particular style is indicated on the rating plate of the motor (symbol ). When filling, make certain that the upper gear unit components, depending upon the installation position, are also well lubricated. The oil level mark should be taken into consideration in special cases. Information about the lubricant volume required for other styles construction can be obtained from the works.

Disposal

The metallic parts of the gear unit and the geared motor can be disposed of as scrap, segregated into steel, iron, aluminium and copper. The lubricants used are to be disposed of as waste oil, and the synthetic oils are to be disposed of as special waste. Information on this can be found on the lubrication chart or the rating plate.

Bearing lubrication for large geared motors

The lubrication periods for rolling contact bearings on the input shaft vary depending on type of storage, temperature, speed, loading etc.

On the larger gear units, therefore, input parts SN 70 to SN 90 and KB 70 to KB 90 are provided with a lubrication device for the input shaft. Each bearing has its own lubrication point (lubricating nipple).

The maximum permissible speed is 1800 rpm. The required lubrication period is 2000 operating hours or 6 months whichever is soonest.

With lubrication intervals up to half a year, the grease filling in the bearing can be supplemented at intervals of 1000 operating hours by periodically adding fresh grease. The complete grease filling must, however, be replaced after three grease top-ups at the latest.

The grease top-up is approximately 30 g, however three times this quantity will be required (approximately 90g) when replacing the grease. When this is done, the surplus used grease should also be removed from the grease outlet chamber.









KLÜBER PETAMO GHY 133 N shall be used as the lubricant.

**Bearing lubrication
for small geared
motors (motor size
less than or equal to
IEC 200)**



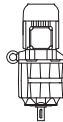

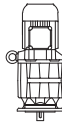
With smaller and middle sized gear units, the input components/motor components are designed with enclosed ball bearings.

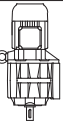
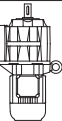
An input speed of 1500 rpm results in a lubrication interval of 10000 operating hours. The maximum permissible speed is 3600 rpm. The lubrication interval is halved in this case. The lubricant change is to be carried out here when the bearings are replaced in the context of maintenance/monitoring of the rotary shaft seals. Cleaning and lubrication of the bearings is not recommended due to the risk of contamination.

Lubrication quantity series BG

Lubrication quantity in l										
Gearbox type										
BG04-BG100	(gear-housing with flange or foot)				Foot with clearance holes (Code-9) [Completely machined (Code -8.)]					
	Flange (Code-2./Code-3./Code-4./Code-7.) Foot with threads (Code-6.)			Foot with clearance holes (Code-9) [Completely machined (Code -8.)]						
	H4	H1	H2	H3	H5	H6	B5	V1	V3	
BG04-BG100										
	(Gearbox housing)				cast-on-foot with clearance holes (Code -1.)					
		B3	B6	B7	B8	V5	V6			
BG04	*	-	0.03	0.03	0.03	-	-	0.03	0.05	0.05
	**	0.05	0.05	0.05	0.05	0.1	0.05	-	-	-
BG05	*	-	0.05	0.05	0.05	-	-	0.05	0.08	0.08
	**	0.08	0.08	0.08	0.08	0.16	0.08	-	-	-
BG06	*	-	0.08	0.08	0.08	-	-	0.08	0.15	0.15
	**	0.12	0.12	0.12	0.12	0.24	0.15	-	-	-
BG10	*	0.65	0.65	0.65	0.85	1.05	0.85	0.65	1.05	0.85
	**	0.45	0.45	0.45	0.6	0.75	0.6	-	-	-
BG20	*	0.8	0.8	0.8	1.1	1.4	1.1	0.8	1.4	1.1
	**	0.6	0.6	0.6	1.0	1.15	0.9	-	-	-
BG30	*	1.0	1.0	1.0	1.7	2.2	1.6	1.0	2.2	1.6
	**	1.0	1.0	1.0	1.7	2.3	1.7	-	-	-
BG40	*	1.7	1.7	1.7	2.5	3.5	2.1	1.7	3.5	2.1
	**	1.7	1.7	1.7	2.5	3.5	2.1	-	-	-
BG50	*	3.0	3.0	3.0	4.5	5.5	3.3	3.0	5.5	3.3
	**	3.0	3.0	3.0	4.5	5.5	3.3	-	-	-
BG60	*	5.5	5.5	5.5	7.0	10.9	6.4	5.5	10.9	6.4
	**	5.5	5.5	5.5	7.0	10.9	6.4	-	-	-
BG70		6.5	6.5	6.5	8.0	13.5	9.0	6.5	13.5	9.0
BG80		11.0	11.0	11.0	11.0	22.5	15.0	11.0	22.5	15.0
BG90		19.0	19.0	19.0	19.0	40.0	26.0	19.0	40.0	26.0
BG100		35.0	35.0	55.0	50.0	66.0	50.0	35.0	66.0	50.0
* Attachment housing										
** Gearbox housing										

Lubrication quantity for BG20-01R

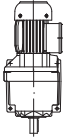
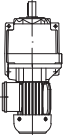
Lubrication quantity in l						
Gear type						
	H4	H1	H2	H3	V5	V6
BG20-01R	0.8	1.0	0.8	1.4	1.65	1.0

Lubrication quantity series BF

Lubrication quantity in l

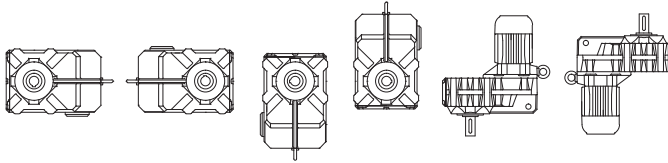

Gear type	H1	H2	H3	H4	V1	V2
BF06	0.25	0.25	0.25	0.37	0.35	0.3
BF10	0.85	0.85	0.85	1.1	1.45	1.5
BF20	1.3	1.3	1.3	1.7	2.2	2.25
BF30	1.7	1.7	1.7	2.2	3.2	3.0
BF40	2.7	2.7	2.7	3.5	4.9	4.8
BF50	3.8	3.8	3.8	5.0	6.7	6.7
BF60	6.7	6.7	6.7	9.0	12.3	12.0
BF70	12.2	12.2	12.2	16.0	24.2	21.8
BF80	17.0	17.0	17.0	21.0	32.2	27.5
BF90	32.0	32.0	32.0	41.0	62.0	53.0

Lubrication quantity series BK

Lubrication quantity in l

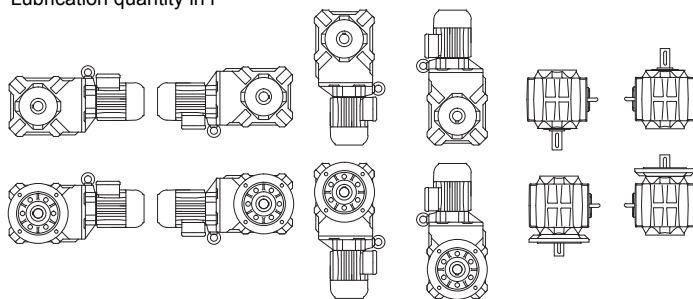

Gear box type	H1	H2	H3	H4	V1	V2
BK06	0.15	0.23	0.29	0.31	0.18	0.23
BK10	0.83	0.83	0.92	1.75	0.92	0.92
BK20	1.5	1.5	1.6	2.9	1.65	1.65
BK30	2.2	2.2	2.3	4.4	2.4	2.4
BK40	3.5	3.5	3.5	6.7	3.7	3.7
BK50	5.8	5.8	5.8	11.5	6.0	6.0
BK60	6.0	8.7	6.9	12.0	8.6	8.6
BK70	10.2	15.0	11.5	20.5	13.5	14.5
BK80	18.0	25.5	19.0	37.0	23.5	25.5
BK90	33.0	48.0	36.0	69.0	45.0	48.0

Lubrication quantity series BS

Lubrication quantity in l

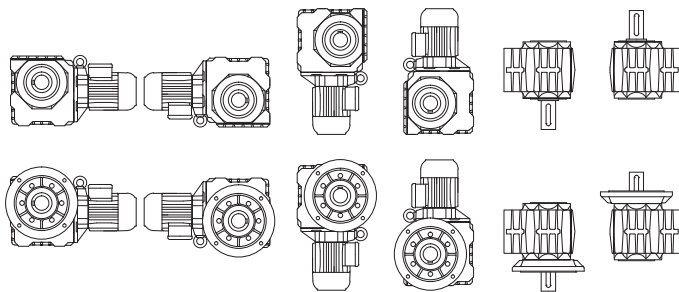

Gear type	H1	H2	H3	H4	V1	V2
BS02	0.06	0.06	0.06	0.06	0.06	0.06
BS03	0.17	0.17	0.17	0.17	0.17	0.17
BS04	0.11	0.17	0.11	0.2	0.11	0.11
BS06	0.24	0.36	0.24	0.45	0.24	0.24
BS10	0.9	1.3	0.9	1.6	0.9	0.9
BS20	1.5	2.1	1.5	2.7	1.5	1.5
BS30	2.2	3.0	2.2	3.8	2.2	2.2
BS40	3.5	4.7	3.5	6.0	3.5	3.5

Lubrication quantity series BM

Lubrication quantity in l

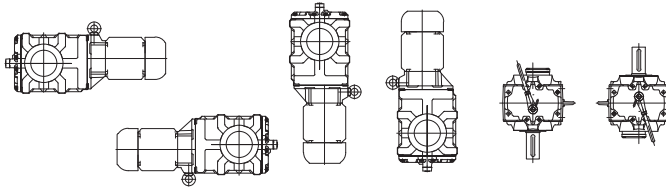

Gearbox type	Lubrication quantity in l					
	H1	H2	H3	H4	V1	V2
BM09	0.5				0.45	0.7
BM10	0.65				0.8	1.3
BM20	0.7				1.0	1.4
BM30	1.2 1.8*				2.4	2.4
BM30/S1	1.2 1.8*	on request			2.4	2.4
BM30/S2	1.3 1.9*				2.7	2.4
BM40	2.5 3.2*				3.0	3.5
BM40/S1	2.5 3.2*				3.0	3.5
BM40/S2	2.6 3.3*				3.3	3.5

*: Lubrication quantity für BM30Z/BM40Z

Caution: if * is shown the lubrication quantity of the pre-stage is filled into the main gear.

Lubrication quantity for coupling lantern

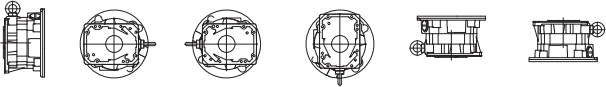
Lubrication quantity in kg													
BG / BF		B3 H4 B5	B6 H1	B7 H2	B8 H3	V5 V1	V6 V3 V2						
BK / BS		H1	V1	V2	H2	H4	H3						
Gear type													
BK06-C / BS06-C		up to IEC200 or up to Nema284/286TC Z-bearing grease lubricated, sealed for life non regreasable											
BG10-BG10Z-C BF10-BF10Z-C BK10-BK10Z-C BS10-BS10Z-C													
BG30-BG30Z-C BF30-BF30Z-C BK30-BK30Z-C BS30-BS30Z-C													
BG50-BG50Z-C BF50-BF50Z-C BK50-BK50Z-C													
BG70-C BF70-C BK70-C													
BG80-C BF80-C BK80-C													
BG90-BG90Z-C BF90-C BK90-BK90Z-C													
BG100-C													
BG70Z-C BG80Z-C BG100Z-C													
BF70Z-C BF80Z-C BF90Z-C													
BK70Z-C BK80Z-C													
BG70-C BK70-C BF70-C BG80-C BK80-C BF80-C BG90-BG90Z-C BK90-BK90Z-C BF90-C BG100-C		only from IEC225 up only from Nema324/326TC up											
		grease lubrication for subsequent lubrication regreasable: (PETAMO GHY133N)											

Lubrication quantity for pre-stage

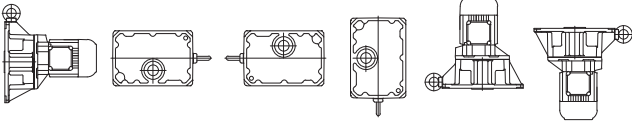
Lubrication quantity in l							
							
BG / BF	B3 H4 B5	B6 H1	B7 H2	B8 H3	V5/H5 V1	V6/H6 V3 V2	
BK / BS	H1	V1	V2	H2	H4	H3	
Gear type							
BG10Z	BF10Z	0.10	0.05	0.12	0.07	0.16	0.07
BK10Z	BS10Z						
BG20Z	BF20Z	0.15	0.07	0.19	0.17	0.27	0.10
BK20Z	BS20Z						
BG30Z	BF30Z	0.2*	0.10	0.35	0.22	0.35	0.19
BK30Z	BS30Z						
BM30Z							
BG40Z	BF40Z	0.32*	0.17	0.50	0.37	0.6	0.32
BK40Z	BS40Z						
BM40Z							
BG50Z	BF50Z	0.5	0.3	0.92	0.7	1.15	0.5
BK50Z							
BG60Z	BF60Z	0.9	0.5	1.55	1.1	2.0	0.7
BK60Z							
BG70Z	BF70Z	1.2	0.6	1.8	1.6	2.4	1.4
BK70Z	BF80Z						
BG80Z	BF90Z	3.1	1.3	4.0	2.6	5.2	2.0
BK80Z	BG100Z						
BG90Z		4.2	1.5	5.4	3.5	7.7	3.0
BK90Z							

*: The lubricant of the pre-stage for BM30Z/BM40Z is filled in the main gearbox.

Lubrication quantity for intermediate gear

Definition of the terminal box position

Terminal box position for intermediate gear is similar to the main gearbox that means
 Main gearbox BG,BF terminal box pos. I
 -> intermediate gearbox terminal box pos. I
 Main gearbox BK,BS terminal box pos. II
 -> intermediate gearbox terminal box pos. II

Lubrication quantity in liquid pint

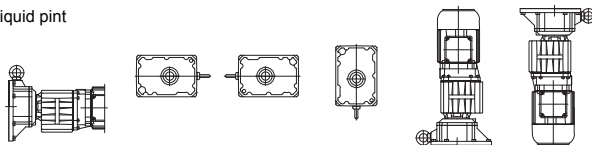

Mounting position of main gearbox	BG / BF	B3 H4 B5	B6 H1	B7 H2	B8 H3	V5/H5 V1	V6/H6 V3 V2	
	BK / BS	H1	V1	V2	H2	H4	H3	
Standard position of KLK mounting position H1, H2, H3, B5, V1, V3 for mounting with screwed resp. casted flange		B5	H1	H2	H3	V1	V3	
Type designation of double gearbox combination								
BG06G04 BK06G04	BS06G04	0.03	0.03	0.03	0.03	0.05	0.05	
BG10G06 BK10G06	BF10G06 BS10G06	0.08	0.08	0.08	0.08	0.15	0.15	
BG20G06 BK20G06	BF20G06 BS20G06	0.08	0.08	0.08	0.08	0.15	0.15	
BG30G06 BK30G06	BF30G06 BS30G06	0.08	0.08	0.08	0.08	0.15	0.15	
BG40G10 BK40G10	BF40G10 BS40G10	0.65	0.65	0.65	0.85	1.05	0.85	
BG50G10 BK50G10	BF50G10	0.65	0.65	0.65	0.85	1.05	0.85	
BG60G20 BK60G20	BF60G20	0.8	0.8	0.8	1.1	1.4	1.1	
BG70G20 BK70G20	BF70G20	0.8	0.8	0.8	1.1	1.4	1.1	
BG80G40 BK80G40	BF80G40	1.7	1.7	1.7	2.5	3.3	2.1	
BG90G50 BK90G50	BF90G50 BG100G50	3.0	3.0	3.0	4.5	5.5	3.3	

Spring-loaded brakes with direct current solenoid release Models E003B and E004B

Safety information

Connection, adjusting and maintenance work may only be carried out taking into account the safety information given on pages 3/4.

These spring loaded brakes are working brakes. The brakes perform frictional work in standard duty e.g. a braking function is performed.

In addition to holding loads in the idle state, the spring-loaded brake slows rotating and linear moving masses, thus reducing unwanted overtravel distances and times.

The brake is released electromagnetically. Under zero-load conditions, braking force is applied by spring pressure. Because braking is still effective even if an accidental power failure occurs, it can be considered a safety brake within the context of accident prevention regulations.

During the braking process, the kinetic energy of the mass moments of inertia is converted into heat via the brake disc. The brake disc, which consists of high-quality, asbestos-free material, is highly resistant to wear and heat. A certain amount of wear is unavoidable, however. For this reason, the limit values specified in paragraph 8 regarding the working capacity and the minimum lining thickness are to be strictly observed.

Operating principle

The operating principle is described in Figure 1.

Brakes

The brake disc (1) is pressed axially through the retaining plate (2) against the friction plate (4) by springs (3). Radial movement of the retaining plate is prevented by the fillister screws (5). The braking torque is transferred to the rotor via gear teeth connecting the brake disc and the carrier (6) fixed to the shaft. The braking torque and the number of springs can be changed in stages (see paragraph 6).

Brake release

Supplying the coil (7) with the correct DC voltage causes the retaining disc to be attracted by the magnetic field generated in the magnet housing (8) against the spring force. This relieves the brake disc and as a result allows the rotor to move freely.

The increased air gap s_L caused by the wear to the brake discs can be overcome thanks to the generous dimensioning of the electromagnets. No adjustment facility is hence provided.

All brakes can be optionally fitted with either a latching or non-latching manual release, which may be used to release the brake manually e.g. in the event of a power failure.

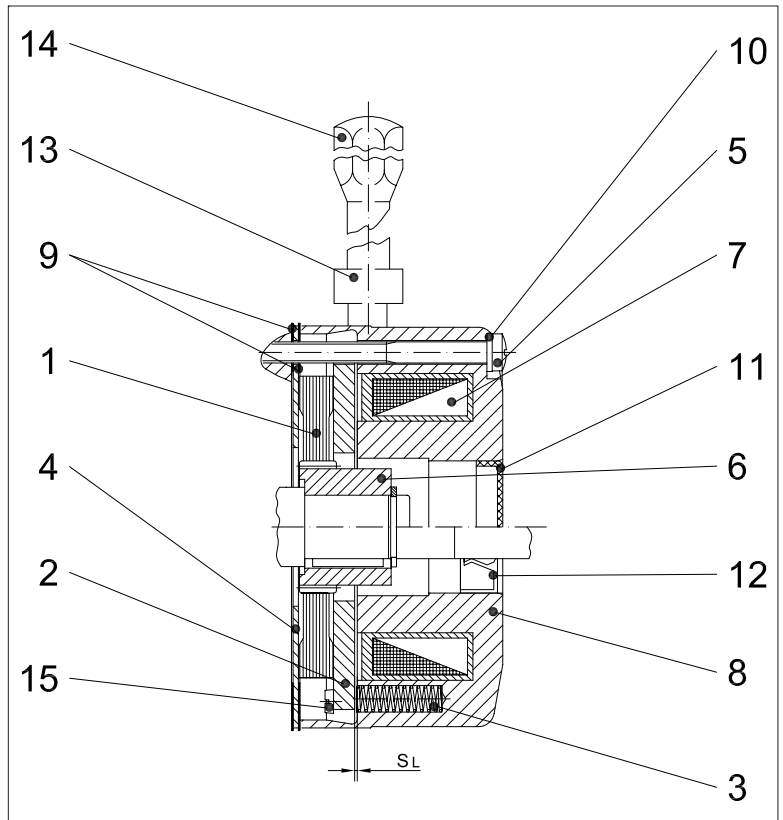

Figure 1: Spring-loaded brake from the series E003B and E004B

Assembly

Generally, the spring-loaded brakes are mounted ready for operation on the motor. Proceed as follows for retrofitting (see Figure 1):

- Fit carrier (6) to the shaft, pay attention to the total supporting length of the keys and fix axially with a retaining ring.
- Push friction plate (4) with both seals (9) and brake disc (1) onto the carrier manually. Ensure that the gearing moves easily.

Do not damage !

- Observe the correct installation position of the friction plate (4): Side with engraved marking "Reibseite" (friction side) facing toward brake disc (1).
- Secure the brake (4) using the fillister screws (5) and the USIT rings (10) over the friction plate and both seals (9) on the end shield of the motor. Observe starting torque, $M_A = 2.5 \text{ Nm}$.
- For motor types without a second shaft end, fit a closure cap (11) and for motor types with a second shaft end, fit a shaft sealing ring (12).

The brake is ready for operation once the electrical connection has been made.

Setting of the brake torque



ATTENTION!

Bauer assumes no liability when the springs are changed.

Different braking torques can be obtained with a different spring configuration in the magnet housing (see paragraph MAINTENANCE).

Request the relevant set of springs from the factory, specifying the brake type and the required braking torque setting.

Procedure for changing the spring configuration (see Figure 1):

- 6.1 Remove brake from the motor end shield.
- 6.2 Remove fastening screws (5).
- 6.3 Unscrew the shoulder screws (15) from the magnet housing (8) and remove the retaining plate (2).



ATTENTION!

The springs (3) press against the retaining plate. To remove the shoulder screws, the retaining plate must be pressed against the magnet housing to avoid releasing the springs too quickly. Observe the installation position of the retaining plate and make sure that no springs fall out.

- 6.4 Insert springs (3) according to desired braking torque (see paragraph MAINTENANCE).



ATTENTION!

The springs should be arranged **symmetrically**.

- 6.5 Place the retaining plate (2) on the magnet housing (8) or springs (3) (observe installation position, if necessary use fastening screws (5) as centring assistance), press the retaining plate down against the spring force and screw in the shoulder screws (15) to the stop.
- 6.6 Secure the brake using the fastening screws (5) and USIT rings (10) above the friction plate (4) and both seals (9) on the end shield of the motor. Observe starting torque, $M_A = 2.5 \text{ Nm}$.

Maintenance

The E003B and E004B brakes are to a large extent maintenance-free, since a very long service life is obtained by the durable and wear resistant brake discs. However, if the brake disc becomes worn due to high total friction and the function of the brake is therefore no longer guaranteed, replacing the brake disc will restore the brake to its original condition.

The state of wear of the brake disc should be checked regularly by measuring the brake disc thickness. This must not fall below the limit value.

Procedure for checking the state of wear and for replacing the brake disc (see Figure 1)

- Remove brake from the motor end shield.
- Remove fastening screws (5).
- Clean brake. Remove abrasion material using compressed air.
- Remove brake disc (1) from the carrier (6).
- Measure the thickness of the brake disc. At the latest, the brake disc is to be replaced when it reaches the minimum thickness.
- Check retaining plate (2) for wear and parallelism (there should be no significant grooving). Replace retaining plate if necessary.
- Push brake disc (1) onto carrier (6) and check for radial play. If there is increased play in the gear teeth between the carrier and brake disc, the carrier must be removed from the shaft and replaced.
- Secure the brake using the fastening screws (5) and USIT rings (10) over the friction plate (4) and both seals (9) on the end shield of the motor. Observe starting torque $M_A = 2.5 \text{ Nm}$.

Technical data

Type	M_{Br} [Nm]	NS	W_{max} [*10 ³ J]	W_{th} [*10 ³ J]	W_L [*10 ⁶ J]	t_A [ms]	t_{AC} [ms]	t_{DC} [ms]	d_{min} [mm]	P_{el} [W]
E003B9	3	4	1,5	36	55	35	150	15	5,85	20
E003B7	2,2	3	1,8	36	90	28	210	20	5,75	20
E003B4	1,5	2	2,1	36	140	21	275	30	5,6	20
E004B9	5	4x red	2,5	60	50	37	125	15	5,87	30
E004B8	4	4x grey	3	60	100	30	160	18	5,75	30
E004B6	2,8	4x yellow	3,6	60	180	23	230	26	5,55	30
E004B4	2	2x grey	4,1	60	235	18	290	37	5,4	30
E004B2	1,4	2x yellow	4,8	60	310	15	340	47	5,2	30

Explanation of abbreviations

M_{Br}	Nominal braking torque. Brake torque tolerance: -10 / +30%
NS	Number of springs Because different springs can be used for the E004B, the colour of the relevant springs must also be specified here.
W_{max}	Maximum permissible switching energy for a single braking operation
W_{th}	Maximum permissible switching energy per hour
W_L	Maximum permissible switching until replacement of the brake disc The values given for W_L are reference values which can vary considerably depending on the specific application. It is recommended to monitor the brake disc thickness regularly.
t_A	Response time when releasing with normal excitation. Overexcitation by the MSG special rectifier results in response times that are approximately half as long.
t_{AC}	Response time when braking with alternating current isolation, i.e. by interruption of the power supply of a separately fed standard rectifier. When the voltage supply of the rectifier results from the motor connection block, considerably higher response times are expected due to the residual magnetism of the motor - dependent on motor size and winding design.
t_{DC}	Response time when braking with direct current interruption by mechanical circuit breaker. Electronic direct-current interruption by a special rectifier (type ESG or MSG) results in response times that are approximately twice as long. Dependent on the operating temperature and the state of wear of the brake disc, the actual response times (t_A , t_{AC} , t_{DC}) can deviate from the guide values indicated here.
d_{min}	Minimum permissible thickness of the brake disc
P_{el}	Electrical power consumption of the solenoid at 20° C Depending on the voltage design of the coil, the actual power can differ from the reference value given.



ATTENTION!

The max. permissible frictional work and the min. permissible brake disc thickness are not valid for brake motors used in potentially explosive areas. Please refer here to the special corresponding documentation for explosion proof motors.

Spring-loaded brakes with DC solenoid release

Models ES(X)010A ... ES(X)250A, ZS(X)300A, ZS(X)500A

Safety information

Connection, adjusting and maintenance work may only be carried out taking into account the safety information on pages 3/4.

General information

The brakes ES010A ... ES250A, ZS300A and ZS500A are holding brakes which do not perform frictional work in standard duty but are used principally for holding a specifically reached position. In emergency situations a braking function may also be performed.

The brakes ESX010A ... ESX250A, ZSX300A and ZSX500A are working brakes which perform frictional work in standard duty e.g. a braking function is performed.

In addition to holding loads in the idle state, the spring-loaded brake slows rotating and linear moving masses, thus reducing unwanted overtravel distances and times.

The brake is released electromagnetically. In the de-energized state, braking force is applied by spring pressure. Because the retardation effect is still effective even if an unforeseen power failure occurs, it can be considered to be a safety brake within the context of accident prevention regulations.

During the braking process, the kinetic energy of the mass moments of inertia is transformed into heat via the brake discs. The brake discs consist of high-quality, asbestos-free material and are particularly resistant to abrasion and heat. A certain amount of wear is, however, unavoidable. For this reason, the limit values regarding the working capacity and the minimum lining thickness are to be strictly observed.

Operating principle

Single disc brakes ES(X)...

The springs (Pos. 3) press the axial movable pressure plate (Pos. 6) and the brake disc (Pos. 2) which is mechanically connected to the rotor shaft against the friction disc or motor end shield. The brake torque is created.

When a DC voltage is placed on the coil in the magnet housing (Pos. 1), a magnetic force is created whereby the pressure plate (Pos. 6) is pulled against the spring force against the magnet housing (Pos. 1). The brake disc is free to run and the brake is opened.

CAUTION!

The air gap of the brake is not adjustable due to the construction principal of the magnet housing. When the wear limit or the max. permissible air gap is reached, the brake disc must be replaced. The momentarily existing air gap of the brake can be determined by means of a feeler gauge after removing the plug (Pos. 13). The plug must be replaced and sealed with locking varnish.

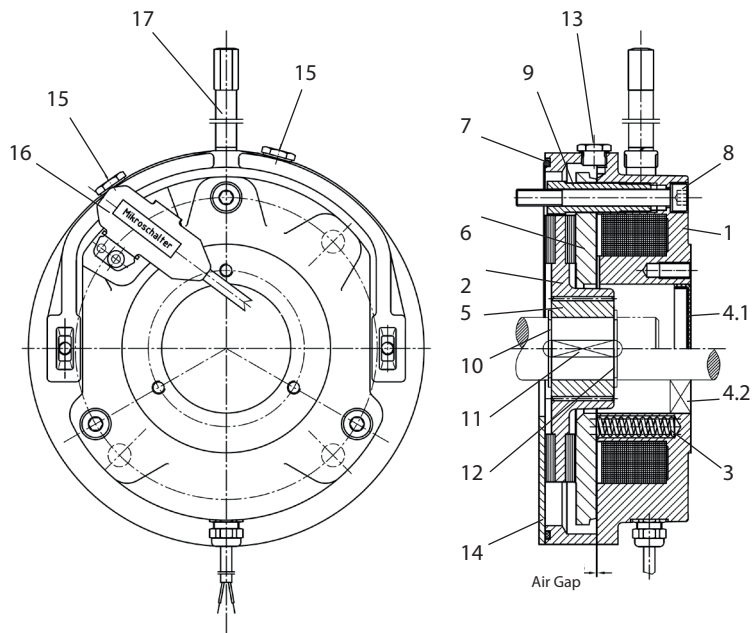

Figure 1: Brake Models ES(X)010A ... ES(X)250A.

- | | |
|-----|--|
| 1 | Magnet housing |
| 2 | Brake disc |
| 3 | Spring |
| 4.1 | Sealing cap for encapsulated brakes |
| 4.2 | Shaft seal for 2nd shaft extension |
| 5 | Carrier |
| 6 | Pressure Plate |
| 7 | O-Ring |
| 8 | Fastening bolts with copper washer |
| 9 | Hollow bolt |
| 10 | Circlip |
| 11 | Key |
| 12 | Circlip |
| 13 | Plug for monitoring of the air gap |
| 14 | Friction plate– only for motor sizes D08 and D09 |
| 15 | Plug for monitoring of the micro switch setting |
| 16 | Microswitch (Optional) |
| 17 | Manual release (Optional) |

Double disc brakes ZS(X)...

The springs (Pos. 3) press the axial movable pressure plate (Pos. 6) and the brake disc (Pos. 2.1 and 2.2) which are mechanically connected to the rotor shaft against the motor end shield. The brake torque is created.

When a DC voltage is placed on the coil in the magnet housing (Pos. 1), a magnetic force is created whereby the pressure plate (Pos. 6) is pulled against the spring force against the magnet housing (Pos. 1). The brake discs (Pos. 2.1 and 2.2) are free to run and the brake is opened.

When the wear limit or the max. permissible air gap is reached, the brake can be adjusted. When worn, the brake can be adjusted. The momentarily existing air gap can be monitored after removal of the sealing ring (Pos. 13).

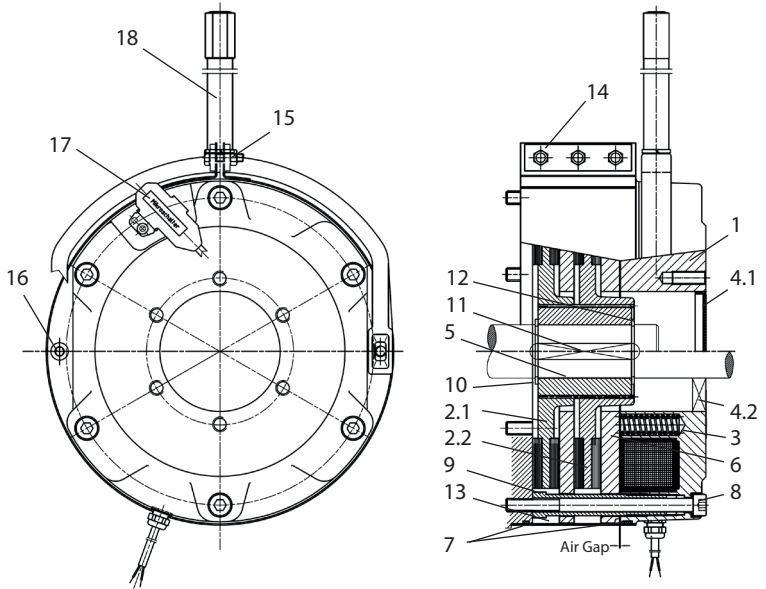

Figure 2: Brake models ZS(X)300A, ZS(X)500A.

1	Magnet housing
2	Brake disc 2.1 and 2.2
3	Spring
4.1	Sealing cap for encapsulated brakes
4.2	Shaft seal for 2nd shaft extension
5	Carrier
6	Pressure Plate
7	O-Ring
8	Fastening bolts with copper washer
9	Hollow bolt
10	Circlip
11	Key
12	Circlip
13	Cover
14	Fastening bolts
15	Plate
16	Assembly screw/Assembly help
17	Microswitch (Optional)
18	Manual release (Optional)

Assembly



ATTENTION!

- Brake disc and brake surface must be free from oil and grease
- The carrier must be positioned so that the spline of the brake disc is in full contact.
- The contacting surface of the key should be along the full length of the carrier.
- Cleaning agents containing solvents may not be used as these corrode the friction material.

The brakes are assembled ready-for-use on the motor.

The assembly of the single disc brakes results as follows:

- Insert the circlip (Pos. 10) in the shaft groove.
- Insert the key (Pos. 11) in the rotor shaft.
- Position the carrier (Pos. 5) on the rotor shaft and secure with the circlip (Pos. 12).
- Assemble friction plate (Pos. 14) (only motor sizes D08 and D09).
- Push the brake disc (Pos. 2) onto the carrier (Pos. 5).
- Assemble the magnet housing with 3 fastening bolts (Pos. 8). Tightening torques refer to Brake Technical Data.

CAUTION!

Copper washers are found under the bolt heads. These may only be used once.

- The air gap of the brake is defined by the brake design.

The assembly of the double disc brakes results as follows:

- Insert circlip (Pos. 10) in the shaft groove.
- Insert key (Pos. 11) in the motor shaft.
- Position carrier (Pos. 5) on the shaft and secure with circlip (Pos. 12).
- Push brake disc (Pos. 2.1) onto the carrier (Pos. 5).
- Push the magnet housing with the intermediate flange and the brake disc (Pos. 2.2.) onto the carrier.
- Tighten the fastening bolts with the given torque. Tightening torque refer to Brake Technical Data.
- The brake air gap must be monitored. Values refer to Brake Technical Data

CAUTION!

Should the air gap not correspond to the given values, it must be set according to section Air Gap.

- Place the O-Rings (Pos. 7) in the corresponding grooves.
- Place the cover (Pos. 13) around the brake.
- Place the plate (Pos. 15) on the lugs of the covering plate.
- Press the cover plate with screws (Pos. 14) so far so that the cover plate lies radially on the magnet housing and the motor end shield.

CAUTION!

Copper washers are found under the bolt heads. These may only be used once.

CAUTION!

The brakes without manual release are supplied with an assembly aid which is to be removed after assembly.

The open holes in the magnet housing must be sealed with the plastic plugs supplied along with the brake.

Air Gap

General

The air gap must be monitored regularly. When the max. permissible air gap is reached (see technical data) the brake disc must be replaced or the air gap adjusted. Adjustment of the air gap is only possible for double disc brakes.

Monitoring the air gap of single disc brakes

The brake air gap (max. permissible air gap refer to Brake Technical Data) can be measured by means of a feeler gauge by removing the plug (Pos. 13). The plug must be replaced and sealed with locking varnish.

CAUTION!

The max. tightening torque of the plug is 10 Nm.

Monitoring of the air gap of double disc brakes

After removal of the cover (Pos. 13), the air gap can be measured by means of a feeler gauge.

Procedure:

- When looking at the brake, the fastening bolts (Pos. 8) must be released by half a turn.
- Now, the hollow bolts (Pos. 9), which enclose the fastening bolts (Pos. 8) can be screwed into the magnet housing (Pos. 1) by turning anticlockwise.
- Turning the 3 fastening screws (Pos. 8), positioned 120° from another, clockwise, the magnet housing can be moved in the direction of the pressure plate (Pos. 6) so that the nominal air gap measured with a feeler gauge is reached. Nominal air gap refer to Brake Technical Data.
- The 3 hollow bolts are now screwed out clockwise until they sit against the magnet housing (Pos. 1).
- Finally the fastening screws (Pos.8) are tightened with the defined tightening torque given in the Brake Technical Data.
- The rest of the hollow bolts of the adjacent friction surface must be carefully tightened with the defined tightening torque.
- The brake air gap must now be rechecked. Values refer to Brake Technical Data.

CAUTION!

The manual release setting may not be changed.

Setting of the brake torque



ATTENTION!

Bauer assumes no liability when the springs are changed.

Single disc brakes ES(X)...

Different brake torques (see Brake Technical Data) can be reached by means of differing spring placement (see figure 7.1) in the magnet housing (Pos. 1).

When the conversion of the brake must result through the user, the required springs (Pos. 3) are to be requested giving the brake size and the brake setting.



ATTENTION!

The brake must be disassembled from the motor and under no-load before the springs are changed.

Disassembly

- Release the fastening screws (Pos. 8) when present.
- Remove the manual release (optional).
- Unscrew the hollow bolts (Pos. 9) out of the magnet housing (Pos. 1).



ATTENTION!

The springs (Pos. 3) press against the pressure plate (Pos. 6). The pressure plate (Pos. 6) must be pressed against the magnet housing (Pos. 1) to avoid an abrupt relief of the springs (Pos. 3).

Assembly

- Remove the springs (Pos. 3).
- Insert the new spring set– positioning see figure 7.1 and figure 7.2

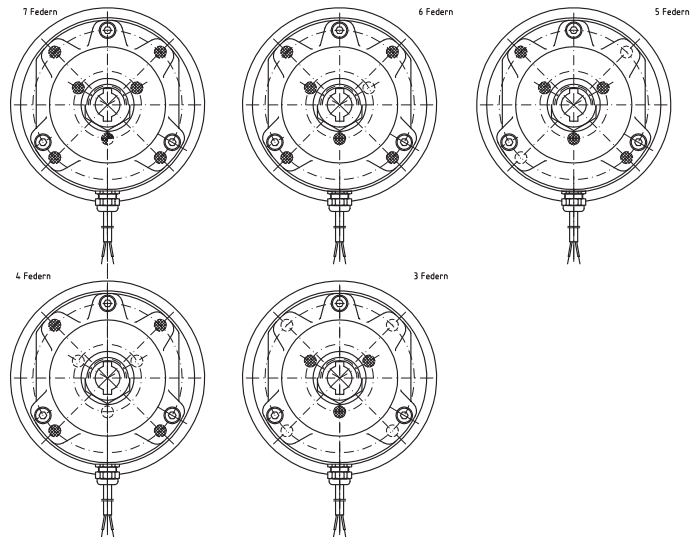

Figure 7.1 Positioning of the springs – Brakes ES(X)010A...ES(X)200A

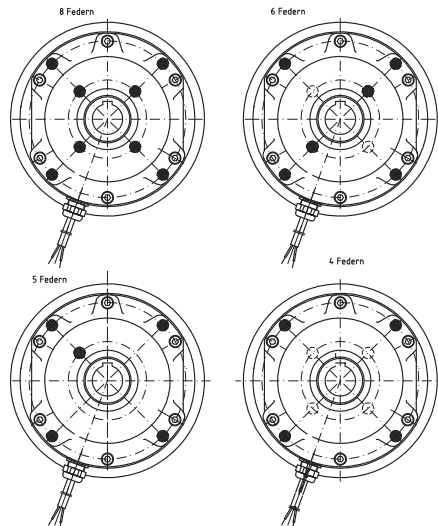

Figure 7.2 Positioning of the springs - Brake ES(X)250A

**ATTENTION!**

If a manual release was present, proceed with the assembly and setting according to the section Manual Release.

- Place the pressure plate (Pos. 6) on the springs (Pos. 3).

**ATTENTION!**

Observe the position of the bore for the manual release.

- Screw in the hollow bolts (Pos. 9) against the spring force until block.
- Assemble the brake on the motor end shield.

**ATTENTION!**

Refer to Brake Technical Data for the tightening torque of the fastening screws (Pos. 8).

Brake check**Checking the air gap**

- Remove plug (Pos. 13).
- Check the air gap by means of a feeler gauge. Air gap refer to Brake Technical Data.
- Replace the plug (Pos. 13).

Double disc brakes ZS(X)...

The brakes ZS(X)300 and ZS(X)500 cannot be modified to other brake torques.

Replacing the brake disc

- Remove the motor and brake from the mains supply. Disconnect the brake supply cable.
- Loosen the fastening screws (Pos. 8) and remove the brake from the motor end shield.
- Clean the brake. Remove brake dust by means of compressed air.
- Remove the brake disc (Pos. 2) from the carrier (Pos. 5).
- Place the new brake disc on the carrier and re-assemble the brake.

Technical Date of the Holding Brakes with Emergency Characteristics Models ES.../ZS...
Frictional Work, Response Time, Power

Type	M_{Br} [Nm]	W_{max} [10 ³ J]	W_{th} [10 ³ J]	W_L [10 ⁶ J]	t_A [ms]	t_{AC} [ms]	t_{DC} [ms]	P_{el} [W]
ES010AX	15*	3	-	-	110	-	30	35
ES010A9	10	3	-	-	60	100	15	
ES010A8	8	3	-	-	55	150	20	
ES010A5	5	3	-	-	45	220	20	
ES010A4	4	3	-	-	30	250	20	
ES010A2	2,5	3	-	-	25	350	25	
ES027AX	32*	2,5	-	-	80	-	30	50
ES027A9	27	2,5	-	-	120	100	15	
ES027A7	20	2,5	-	-	100	130	20	
ES027A6	16	2,5	-	-	80	170	25	
ES040A9	40	3,5	-	-	100	100	20	65
ES040A8	34	3,5	-	-	80	200	25	
ES040A7	27	3,5	-	-	70	250	30	
ES070AX	90*	3,5	-	-	120	-	40	85
ES070A9	70	3,5	-	-	120	150	18	
ES070A8	63	3,5	-	-	120	200	20	
ES070A7	50	3,5	-	-	90	220	25	
ES125A9	125	4,5	-	-	170	220	25	105
ES125A8	105	4,5	-	-	150	320	28	
ES125A7	85	4,5	-	-	135	350	30	
ES125A6	70	4,5	-	-	120	440	35	
ES125A5	57	4,5	-	-	100	600	40	
ES125A3	42	4,5	-	-	90	700	45	
ES200A9	200	8	-	-	400	150	22	105
ES200A8	150	8	-	-	280	250	35	
ES200A7	140	8	-	-	200	320	35	
ES250AX	350*	9	-	-	180	-	70	135
ES250A9	250	9	-	-	300	500	45	
ES250A8	200	9	-	-	200	960	60	
ES250A6	150	9	-	-	160	1100	60	
ES250A5	125	9	-	-	150	1500	90	
ES250A4	105	9	-	-	130	1800	110	
ZS300A9	300	8	-	-	280	220	35	75
ZS300A8	250	8	-	-	210	380	45	
ZS500A9	500	9	-	-	320	320	50	100
ZS500A8	400	9	-	-	260	600	60	

* only permissible with MSG-Rectifier, over excitation is required

Explanation of abbreviations

M_{Br}	Nominal braking torque. Brake torque tolerance: -10 / +30%
W_{max}	Maximum permissible switching energy for a single braking operation
W_{th}	Maximum permissible switching energy per hour
W_L	Maximum permissible switching until replacement of the brake disc

No values given for W_{th} and W_L as the holding brakes in standard duty do not perform frictional work.

t_A	Response time when releasing with normal excitation. Overexcitation by the MSG special rectifier results in response times that are approximately half as long.
t_{AC}	Response time when braking with alternating current isolation, i.e. by interruption of the power supply of a separately fed standard rectifier. When the voltage supply of the rectifier results from the motor connection block, considerably higher response times are expected due to the residual magnetism of the motor - dependent on motor size and winding design.
t_{DC}	Response time when braking with direct current interruption by mechanical circuit breaker. Electronic direct-current interruption by a special rectifier (type ESG or MSG) results in response times that are approximately twice as long.

For the brake torque designs marked with *, which can only be reached by use of the MSG rectifier, the values for t_A and t_{DC} are already valid for use with the MSG rectifier i.e. t_A for over excitation and t_{DC} for electrical DC switching.

Depending on the operating temperature and the production tolerances, the actual response times can differ from the guidance values given here.

P_{el}	Electrical power consumption of the solenoid at 20° C Depending on the voltage design of the coil, the actual power can differ from the reference value given.
----------	---

Spring placement, Air Gap, Tightening torque of the screws

Type	M _{Br} [Nm]	Number and colour of the springs		s _{LN} [mm]	s _{Lmax} [mm]		M _A [Nm]
		outside	inside		w/o HL	with HL	
ES010AX	15* ¹⁾	Special		0,2	0,6	0,6	6
ES010A9	10	4x yellow	3x black	0,2	0,6	0,6	
ES010A8	8	4x yellow	3x yellow	0,2	0,7	0,7	
ES010A5	5	2x yellow	3x yellow	0,2	1,0	1,0	
ES010A4	4	4x yellow	-	0,2	1,2	1,0	
ES010A2	2,5	4x blue	3x blue	0,2	1,5	1,0	
ES027AX	32* ¹⁾	Special		0,3	0,6	0,6	10
ES027A9	27	4x black	3x black	0,3	0,6	0,6	
ES027A7	20	4x yellow	3x black	0,3	0,9	0,9	
ES027A6	16	4x black	-	0,3	1,0	1,0	
ES040A9	40	4x blue	3x blue	0,3	0,9	0,9	10
ES040A8	34	4x blue	2x blau	0,3	1,1	1,0	
ES040A7	27	2x blue	3x blue	0,3	1,3	1,0	
ES070AX	90*	4x black	3x black	0,3	1,0	1,0	25
ES070A9	70	2x black	3x black	0,3	0,8	0,8	
ES070A8	63	4x yellow	3x yellow	0,3	1,1	1,0	
ES070A7	50	4x yellow	2x yellow	0,3	1,5	1,0	
ES125A9	125	4x yellow	3x black	0,4	0,7	0,7	25
ES125A8	105	2x yellow	3x black	0,4	1,2	1,2	
ES125A7	85	4x yellow	2x yellow	0,4	1,3	1,2	
ES125A6	70	2x yellow	3x yellow	0,4	1,7	1,2	
ES125A5	57	4x yellow	-	0,4	2,0	1,2	
ES125A3	42	-	3x yellow	0,4	2,0	1,2	
ES200A9	200 ¹⁾	Special		0,4	0,6	0,6	25
ES200A8	150	4x yellow	3x yellow	0,4	0,9	0,9	
ES200A7	140	4x yellow	2x yellow	0,4	1,2	1,2	
ES250AX	350*	4x black	4x black	0,5	0,9	0,9	50
ES250A9	250	4x yellow	4x yellow	0,5	1,0	1,0	
ES250A8	200	4x yellow	2x yellow	0,5	1,7	1,5	
ES250A6	150	4x yellow	1x yellow	0,5	2,0	1,5	
ES250A5	125	4x yellow	-	0,5	2,4	1,5	
ES250A4	105	4x blue	4x blue	0,5	2,4	1,5	
ZS300A9	300	4x yellow	3x yellow	0,5	0,9	0,9	25
ZS300A8	250	2x yellow	3x yellow	0,5	1,1	1,1	
ZS500A9	500	4x yellow	4x yellow	0,5	1,0	1,0	50
ZS500A8	400	4x yellow	2x yellow	0,5	1,2	1,2	

* only permissible with MSG-Rectifier, over excitation is required

¹⁾ Brake with special spring bore. Reworking to another brake torque is not possible.

Explanation of abbreviations

M_{Br}	Nominal braking torque. Brake torque tolerance: -10 / +30%
s_{LN}	Nominal air gap when new. Tolerance +0,15 mm
s_{Lmax}	Maximum permissible air gap
HL	Manual Release
M_A	Tightening torque of the fastening screws



ATTENTION!

The max. permissible frictional work and the min. permissible brake disc thickness are not valid for brake motors used in potentially explosive areas. Please refer here to the special corresponding documentation for explosion proof motors.

Technical Data of the Working Brakes Models ES(X).../ZS(X)...

Frictional Work, Response Time, Power

Typ	M _{Br} [Nm]	W _{max} [10 ³ J]	W _{th} [10 ³ J]	W _L [10 ⁶ J]		t _A [ms]	t _{AC} [ms]	t _{DC} [ms]	P _{ei} [W]
				ohne HL	mit HL				
ESX010AX	15*	3	250	120	120	110	-	30	35
ESX010A9	10	3	250	120	120	60	100	15	
ESX010A8	8	3	250	150	150	55	150	20	
ESX010A5	5	3	250	240	240	45	220	20	
ESX010A4	4	3	250	300	240	30	250	20	
ESX010A2	2,5	3	250	390	240	25	350	25	
ESX027AX	27*	10	350	150	150	80	-	30	50
ESX027A9	22	10	350	150	150	120	100	15	
ESX027A7	16	10	350	300	300	100	130	20	
ESX027A6	13	10	350	350	350	80	170	25	
ESX040A9	32	20	450	420	420	100	100	20	
ESX040A8	27	20	450	560	490	80	200	25	65
ESX040A7	22	20	450	700	490	70	250	30	
ESX070AX	72*	28	550	700	700	120	-	40	
ESX070A9	58	28	550	500	500	120	150	18	
ESX070A8	50	28	550	800	700	120	200	20	
ESX070A7	40	28	550	1200	700	90	220	25	
ESX125AX	100*	40	700	1900	1900	100	-	70	105
ESX125A9	85	40	700	1700	1700	150	320	28	
ESX125A8	70	40	700	1900	1700	135	350	30	
ESX125A7	58	40	700	2700	1700	120	440	35	
ESX125A5	45	40	700	3300	1700	100	600	40	
ESX125A3	34	40	700	3300	1700	90	700	45	
ESX200AX	160*	60	850	2000	2000	105	-	70	
ESX200A9	120	60	850	1700	1700	280	250	35	
ESX200A8	110	60	850	2600	2600	200	320	35	
ESX250AX	280*	84	1000	2300	2300	180	-	70	135
ESX250A9	200	84	1000	2800	2800	300	500	45	
ESX250A8	160	84	1000	6800	5700	200	960	60	
ESX250A6	120	84	1000	8500	5700	160	1100	60	
ESX250A5	100	84	1000	11000	5700	150	1500	90	
ESX250A4	85	84	1000	11000	5700	130	1800	110	
ZSX300A9	250	60	850	1300	1300	280	220	35	
ZSX300A8	200	60	850	2000	2000	210	380	45	
ZSX500A9	400	84	1000	2800	2800	320	320	50	100
ZSX500A8	320	84	1000	4000	4000	260	600	60	

* only permissible with MSG-Rectifier, over excitation is required

Explanation of abbreviations

M_{Br}	Nominal braking torque. Brake torque tolerance: -20 / +30% when worn in. In new state up to -30% possible
W_{max}	Maximum permissible switching energy for a single braking operation
W_{th}	Maximum permissible switching energy per hour
W_L	Maximum permissible switching until serviceing i.e. replacement of the brake disc or air gap adjustment. Adjustment of the air gap only possible for ZS(X) brakes possible
HL	Manual release

The values given for W_L are reference values which can vary considerably depending on the specific application. It is recommended to monitor the brake disc thickness regularly.



ATTENTION!

The max. permissible frictional work and the min. permissible brake disc thickness are not valid for brake motors used in potentially explosive areas. Please refer here to the special corresponding documentation for explosion proof motors.

t_A	Response time when releasing with normal excitation. Overexcitation by the MSG special rectifier results in response times that are approximately half as long.
t_{AC}	Response time when braking with alternating current isolation, i.e. by interruption of the power supply of a separately fed standard rectifier. When the voltage supply of the rectifier results from the motor connection block, considerably higher response times are expected due to the residual magnetism of the motor - dependent on motor size and winding design.
t_{DC}	Response time when braking with direct current interruption by mechanical circuit breaker. Electronic direct-current interruption by a special rectifier (type ESG or MSG) results in response times that are approximately twice as long.

For the brake torque designs marked with *, which can only be reached by use of the MSG rectifier, the values for t_A and t_{DC} are already valid for use with the MSG rectifier i.e. t_A for over excitation and t_{DC} for electrical DC switching.

Depending on the operating temperature, wear of the brake disc and the production tolerances, the actual response times can differ from the guidance values given here.

P_{el}	Electrical power consumption of the solenoid at 20° C Depending on the voltage design of the coil, the actual power can differ from the reference value given.
----------	---

Spring placement, Air Gap, Tightening torque of the screws

Type	M _{Br} [Nm]	Number and colour of the springs		s _{LN} [mm]	s _{Lmax} [mm]		M _A [Nm]
		outside	inside		w/o HL	with HL	
ESX010AX	15* ¹⁾	Special		0,2	0,6	0,6	6
ESX010A9	10	4x yellow	3x black	0,2	0,6	0,6	
ESX010A8	8	4x yellow	3x yellow	0,2	0,7	0,7	
ESX010A5	5	2x yellow	3x yellow	0,2	1,0	1,0	
ESX010A4	4	4x yellow	-	0,2	1,2	1,0	
ESX010A2	2,5	4x blue	3x blue	0,2	1,5	1,0	
ESX027AX	27* ¹⁾	Special		0,3	0,6	0,6	10
ESX027A9	22	4x black	3x black	0,3	0,6	0,6	
ESX027A7	16	4x yellow	3x black	0,3	0,9	0,9	
ESX027A6	13	4x black	-	0,3	1,0	1,0	
ESX040A9	32	4x blue	3x blue	0,3	0,9	0,9	
ESX040A8	27	4x blue	2x blue	0,3	1,1	1,0	10
ESX040A7	22	2x blue	3x blue	0,3	1,3	1,0	
ESX070AX	72*	4x black	3x black	0,3	1,0	1,0	
ESX070A9	58	2x black	3x black	0,3	0,8	0,8	
ESX070A8	50	4x yellow	3x yellow	0,3	1,1	1,0	
ESX070A7	40	4x yellow	2x yellow	0,3	1,5	1,0	
ESX125AX	100*	4x yellow	3x black	0,4	1,3	1,3	25
ESX125A9	85	2x yellow	3x black	0,4	1,2	1,2	
ESX125A8	70	4x yellow	2x yellow	0,4	1,3	1,2	
ESX125A7	58	2x yellow	3x yellow	0,4	1,7	1,2	
ESX125A5	45	4x yellow	-	0,4	2,0	1,2	
ESX125A3	34	-	3x yellow	0,4	2,0	1,2	
ESX200AX	160* ¹⁾	Special		0,4	1,0	1,0	
ESX200A9	120	4x yellow	3x yellow	0,4	0,9	0,9	
ESX200A8	110	4x yellow	2x yellow	0,4	1,2	1,2	
ESX250AX	280*	4x black	4x black	0,5	0,9	0,9	50
ESX250A9	200	4x yellow	4x yellow	0,5	1,0	1,0	
ESX250A8	160	4x yellow	2x yellow	0,5	1,7	1,5	
ESX250A6	120	4x yellow	1x yellow	0,5	2,0	1,5	
ESX250A5	100	4x yellow	-	0,5	2,4	1,5	
ESX250A4	85	4x blue	4x blue	0,5	2,4	1,5	
ZSX300A9	250	4x yellow	3x yellow	0,5	0,9	0,9	
ZSX300A8	200	2x yellow	3x yellow	0,5	1,1	1,1	
ZSX500A9	400	4x yellow	4x yellow	0,5	1,0	1,0	50
ZSX500A8	320	4x yellow	2x yellow	0,5	1,2	1,2	

* only permissible with MSG-Rectifier, over excitation is required

¹⁾ Brake with special spring bore. Reworking to another brake torque is not possible.

Explanation of abbreviations

M_{Br}	Nominal braking torque. Brake torque tolerance: -20 / +30% when worn in. In new state up to -30% possible
s_{LN}	Nominal air gap when new. Tolerance +0,15 mm
s_{Lmax}	Maximum permissible air gap
HL	Manual Release
M_A	Tightening torque of the fastening screws



ATTENTION!

The max. permissible frictional work and the min. permissible brake disc thickness are not valid for brake motors used in potentially explosive areas. Please refer here to the special corresponding documentation for explosion proof motors.

Electrical brake connection

General

There are 2 different options for the voltage supply of the DC solenoid:

1. Externally from an existing DC control power supply, or from a rectifier in the control cabinet.
2. From a rectifier built into the motor terminal box or brake terminal box. In this instance, the rectifier can be supplied either directly from the motor terminal board or from the mains.

In the following instances, the rectifier must not however be connected to the motor terminal board:

- Pole-changing motors and wide range motors
- Operation with frequency converter
- Other designs in which the motor voltage is not constant, e.g. operation on smooth-start equipment, starting transformers, ...

Brake Release

If the solenoid is energised using nominal voltage, the coil current and the magnetic field build up follow an exponential function. Only when the power has achieved a specific value (I_{Rel}) is the spring force overcome and the brake begins to release.

Two different cases can occur during response time t_r , assuming the power is supplied to the motor and the brake at the same time:

- Motor is blocked - condition: $M_A < M_L + M_{Br}$
The motor takes the inrush current and is thereby subjected to additional thermal loading.
This scenario is shown in Figure 2.
- Motor tears away from brake - condition: $M_A > M_L + M_{Br}$
At the start, the brake is subject to thermal loading and wears more rapidly.

M_A : starting torque of the motor, M_L : load torque, M_{Br} : braking torque

In both scenarios, the motor and brake are therefore subjected to additional loading. The response time becomes noticeably longer as the size of the brakes increases. A reduction in response time is therefore especially recommended for medium and large-sized brakes as well as with a high frequency of braking operations. A relatively simple electrical solution is possible using the principle of 'overexcitation'. In this instance, the solenoid is briefly supplied with twice the nominal voltage when switched on.

The response time is decreased to approximately half by comparison with 'normal excitation' as a result of the associated steeper rise of the current. This overexcitation function is integrated in the MSG special rectifier (see section brake connection).

As the air gap gets larger, the release current and therefore the response time increase. As soon as the release current exceeds the nominal coil current, the brake no longer releases during normal excitation and the brake disc wear limit is reached.

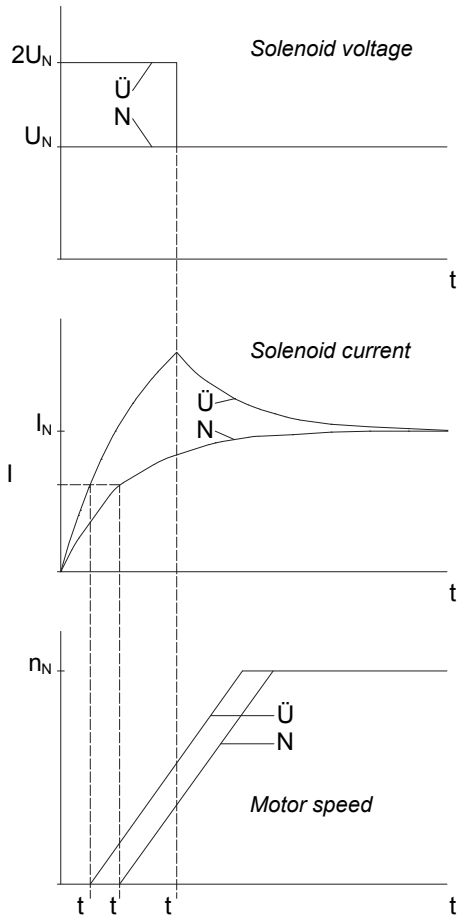

Figure 2: Solenoid voltage, solenoid current and motor speed development at normal excitation (N) and overexcitation (Ü).

$t_{Ü}$: overexcitation period; t_{AN} , $t_{AÜ}$: response times at normal excitation and overexcitation

Braking

The braking torque is not effective immediately after the power supply to the solenoid is switched off. Firstly, the magnetic energy has to reduce until the spring force can overcome the magnetic force. This occurs at holding amperage I_{Hold} which is far smaller than the release current. Dependent on the circuit design, different response times result.

Switching off the AC supply of the standard rectifier SG

- a) Rectifier supply from the motor terminal board (Figure 3, graph 1)
Response time t_{A1} : very long
Cause: after the motor voltage is switched off, the remanence of the motor induces a slowly decaying voltage which continues to supply the rectifier and thus the brake. The magnetic energy of the brake solenoid declines relatively slowly through the freewheeling circuit of the rectifier.
- b) Separate rectifier supply (Figure 3, graph 2)
Response time t_{A2} : long
Cause: after the rectifier voltage is switched off, the magnetic energy of the brake solenoid declines relatively slowly through the freewheeling circuit of the rectifier.

No significant shut-off voltages arise on the solenoid during an AC interruption.

Interruption in the DC switching circuit of the solenoid (Figure 3, graph 3)

- a) By mechanical switch
 - for separate supply from a DC control network or
 - at the DC switching contacts (A2, A3) of the standard rectifierResponse time t_{A3} : very short
Cause: The magnetic energy of the brake solenoid is rapidly reduced by the arc developing at the switch.
- b) Electronically
By use of a special rectifier, type ESG or MSG Response time t_{A3} : short
Cause: the magnetic energy of the brake solenoid is reduced rapidly by a varistor integrated in the rectifier.

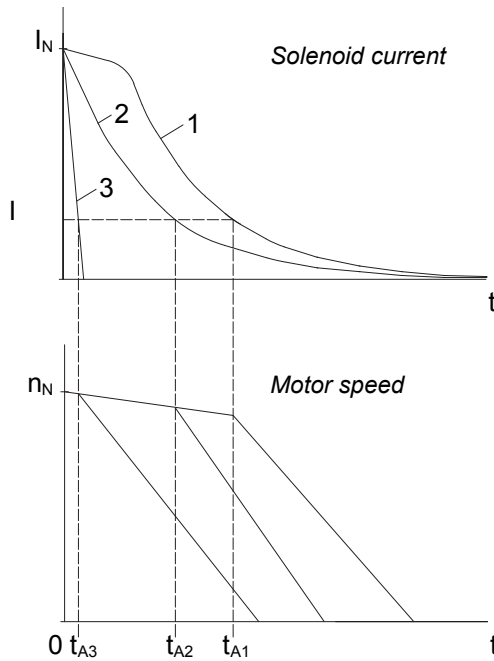

With a DC interruption, voltage spikes u_q are induced through the solenoid the height of which depends on the following relationship between the self-inductance L of the coil and the cut-off speed di/dt :

$$u_q = L \cdot \frac{di}{dt}$$

As a consequence of the winding design, inductivity L increases as the solenoid rated voltage increases. With higher solenoid voltages, the cut-off voltage spikes may therefore be dangerously high. All brakes for voltages in excess of 24 V are therefore connected with a varistor.

The varistor serves only to protect the solenoid and not as protection for the surrounding electronic components and devices against electromagnetic compatibility interference.

On request, brakes for voltages of less than or equal to 24 V can also be produced with varistors.

If the direct current interruption is produced by a mechanical switch, high levels of burn down are caused by the arc produced on the switch contacts. Only special DC direct current contactors or adapted AC alternating current contactors can be used with contacts of usage category AC3 as defined in EN 60947-4-1.

Brake connection: special rectifier ESG 1.460A

1 Via special rectifier ESG 1.460A

Rectifier technical data

Operating principle	Half-wave rectifier with electronic direct current interruption
Supply voltage U_1	220 - 460 V AC $\pm 5\%$, 50/60 Hz
Output voltage	$0.45 * U_1$ V DC
Maximum output current	1 A DC
Ambient temperature	-20°C to 40°C
Possible conductor cross-sections	maximum 1.5 mm ²

The blue conductor routed out of the casing must be connected to PE to activate the integrated high-speed switch-off function.

As this conductor is coupled to the supply voltage with high impedance, leakage currents of up to a maximum of 2 mA may flow, depending on the voltage level.

When operating on unearthed networks, the blue conductor is to be connected with the right alternating current voltage contact (N) of the ESG. If the rectifier is supplied from the motor terminal board in this case, an increase in the response time on shut-down is to be anticipated.

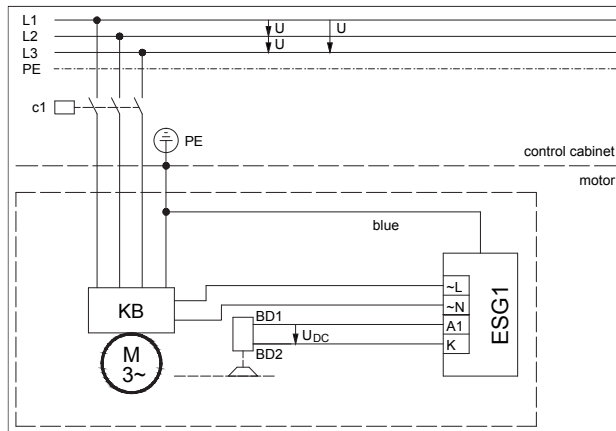
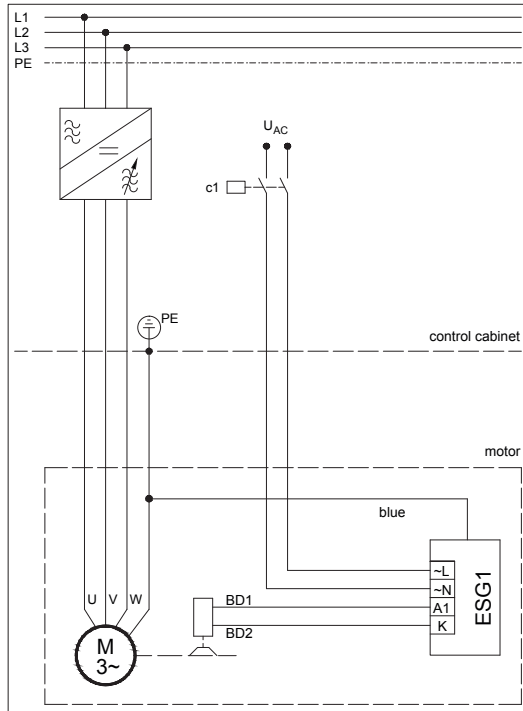

Figure 8: Rectifier voltage supply from the motor terminal board Voltage connection for the rectifier from the motor terminal block or cage clamp (see Rectifier Connection on Motor Terminal Block or Cage Clamp)



Picture 8a: Separate voltage supply of the rectifier, e.g. for usage on frequency inverter

Brake connection: DC voltage supply

If the brake is supplied directly from a DC control power supply.

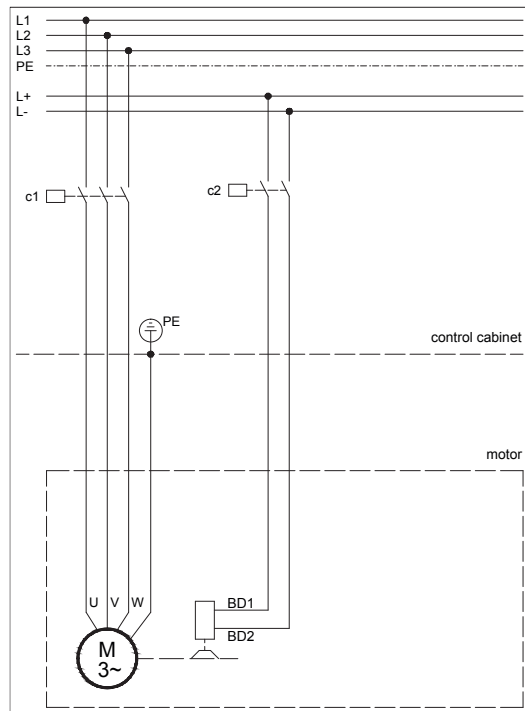

Figure 4: Direct DC power supply from a control network

Brake connection: special rectifier MSG...I

Rectifier technical data MSG 1.5.480I

Operating principle	Half-wave rectifier with time-limited overexcitation and electronic direct current interruption Quick switch-off due to absence of motor current in a phase.
Operating voltage U_1	220 - 480 V AC +6/-10%, 50/60 Hz
Output voltage	$0.9 * U_1$ V DC during overexcitation $0.45 * U_1$ V DC after overexcitation
Overexcitation period	0.3 s
Maximum output current	1,5 A DC
Ambient temperature	-20°C to 40°C
Possible conductor cross-sections	maximum 1.5 mm ²

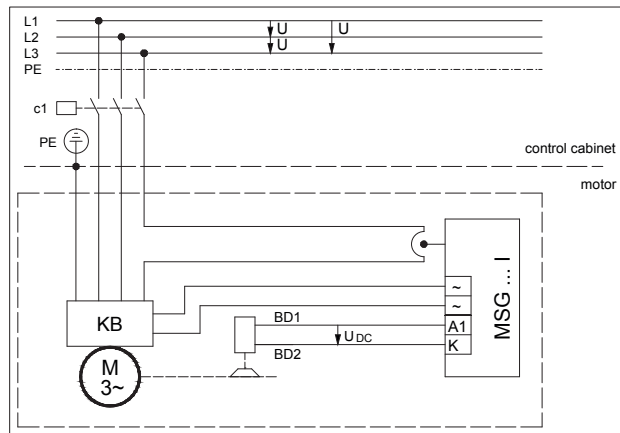
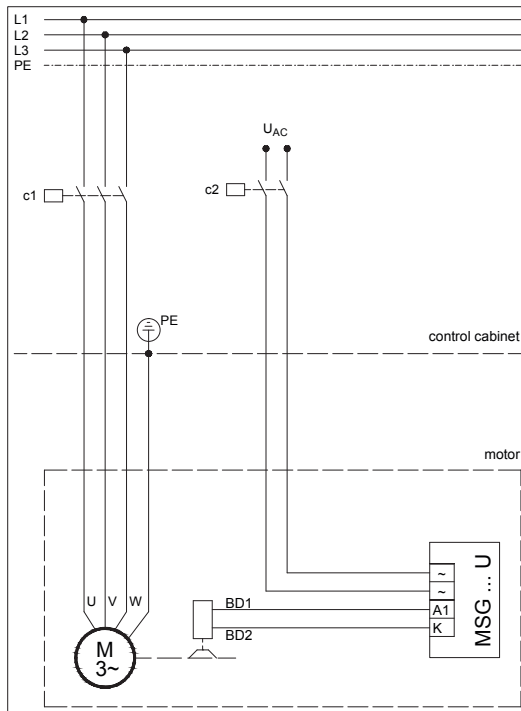

Figure 10: Voltage connection for the rectifier from the motor terminal block or cage clamp (see Rectifier Connection on Motor Terminal Block or Cage Clamp)

Brake connection: special rectifier MSG...U

Rectifier technical data MSG 1.5.500U

Operating principle	Half-wave rectifier with time-limited overexcitation and electronic direct current interruption Quick shut-down due to absence of input voltage.
Operating voltage U_1	220 - 500 V AC +/-10%, 50/60 Hz
Output voltage	$0.9 * U_1$ V DC during overexcitation $0.45 * U_1$ V DC after overexcitation
Overexcitation period	0.3 s
Maximum output current	1,5 A DC
Ambient temperature	-20°C to 40°C
Possible conductor cross-sections	maximum 1.5 mm ²



Picture 9: Separate voltage supply of the rectifier

Brake connection: standard rectifier SG 3.575B

Rectifier technical data

Operating principle	Half-wave rectifier
Supply voltage U_1	maximum 575 V AC +5%, 50/60 Hz
Output voltage	$0.45 * U_1$ V DC
Maximum output current	2 A DC
Ambient temperature	-40°C to 40°C
Possible conductor cross-sections	max. 1.5 mm ²

1 Rectifier voltage supply from the motor terminal board Voltage connection for the rectifier from the motor terminal block or cage clamp (see Rectifier Connection on Motor Terminal Block or Cage Clamp)

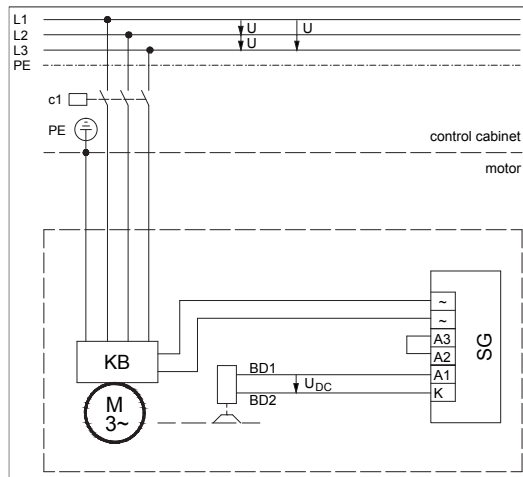

Figure 5: AC disconnection → Terminal A2 and A3 bridged

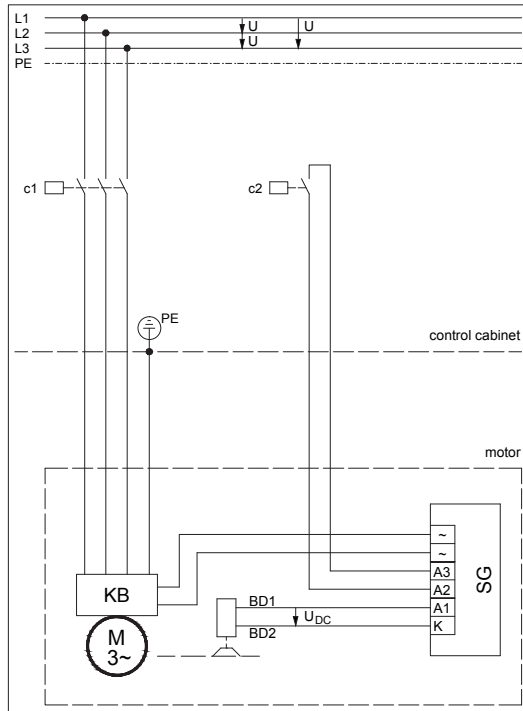

Figure 6: DC disconnection at terminals A2 and A3 e.g. via direction of rotation contactor via relay

2 Rectifier voltage supply via separate contactor

As described in paragraph 4.1, the rectifier may not be connected at the motor terminal board on all models with variable motor voltage or on pole changing motors. Instead, the input voltage of the rectifier must be connected through a separate contactor. The implementation principle when operating on the frequency inverter is shown in Figure 7 and 7a by way of example.

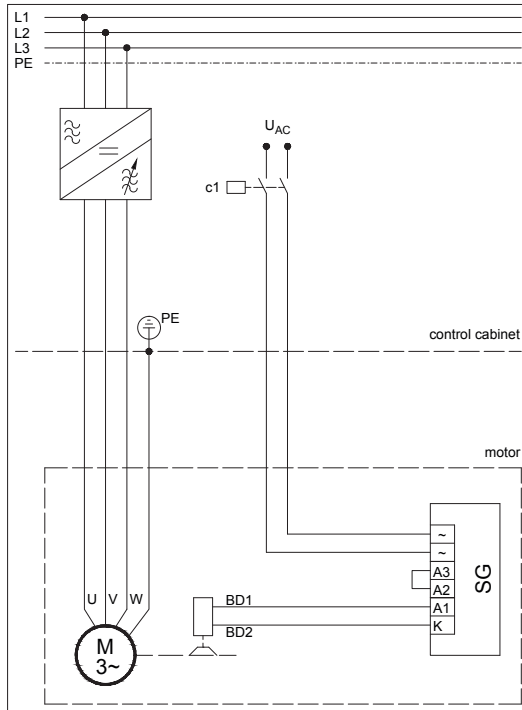
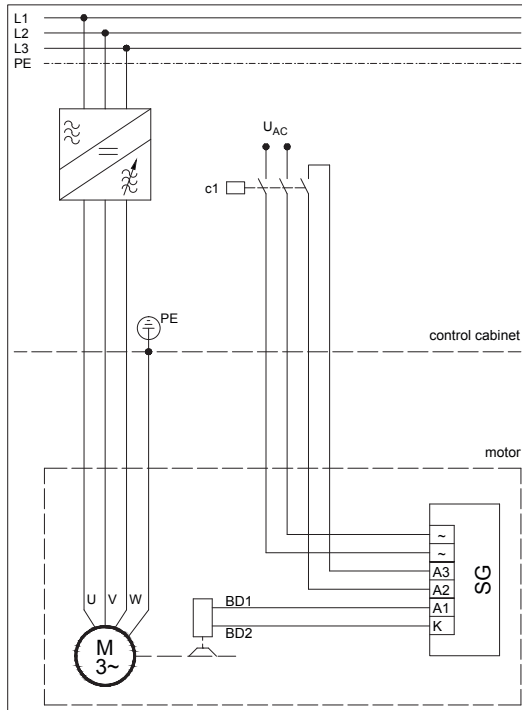
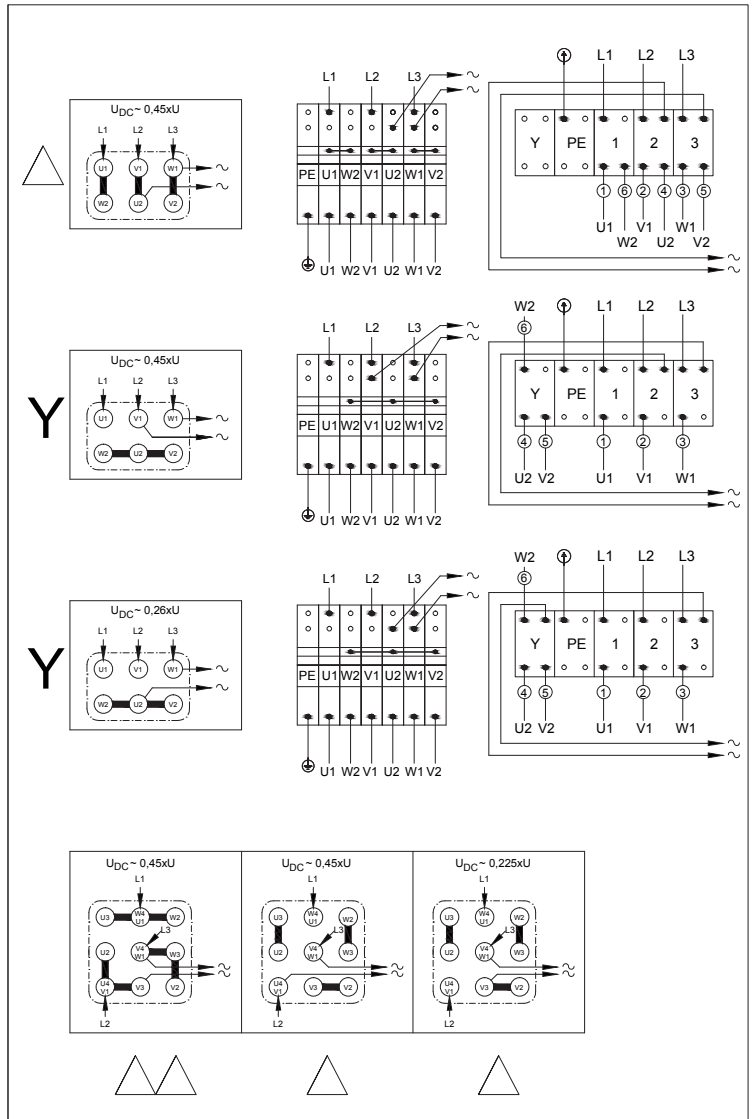

Figure 7: Separate voltage supply of the rectifier.
Alternating current switch-off → Terminals A2 and A3 bridged



Picture 7a: Separate voltage supply of the rectifier. DC side switching on the terminals A2 and A3 via relay.

Rectifier on motor terminal block or cage clamp



Manual release for spring loaded brake with DC solenoid Model E003B and E004B

Assembly

The manual release can only be assembled with the rake removed.

Procedure (see Figures 1 and 12 in section spring loaded E003B and E004B):

- 1.1 Remove brake from the motor end shield.
- 1.2 Remove stopper plugs from the manual-release holes in the magnet housing (8).
- 1.3 Push compression springs (16) onto the manual-release bolts (17).
- 1.4 Push manual-release bolts (17) with compression springs (16) into the manual-release holes on the magnet housing (8) from the inside (in the direction of the coil (7)).
- 1.5 Push the O-rings (18) onto manual-release bolts (17) and push into the countersinks on the magnet housing (8).
- 1.6 Push spacer plates (19) onto the manual-release bolts (17).
- 1.7 Locate manual release bracket (13), push on washer (20) and screw on self-locking nut (21) loosely.
- 1.8 Tighten both lock nuts (21) until the retaining plate (2) is flush with the magnet housing (8).
- 1.9 With non-lockable manual release:
Unscrew both lock nuts (21) by 1.5 turns, thereby creating the air gap between the retaining plate (2) and magnet housing (8) and the test dimension $X = 0.9$ mm.
With latching manual release:
Unscrew both lock nuts (21) by 3 turns, thereby creating the test dimension $X = 2$ mm.
- 1.10 After fitting the fan cowl, screw the manual-release rod (14) into manual-release bracket (13) and tighten.

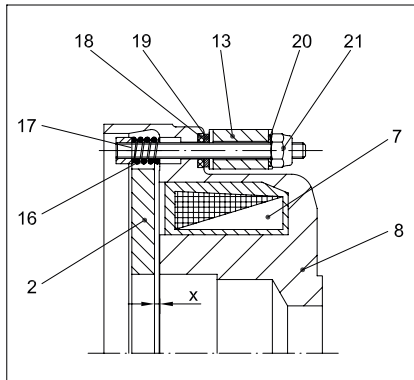

Fig 12: Assembly of the manual release

Function

The manual release bracket (13) is pressed by the compression springs (16) into the neutral position. The brake can be released by axial manipulation.

For the model with a latching manual release, the manual release bracket is fixed by screwing the manual release rod (14) into the appropriate bore in the brake housing with the brake released.

To release the latch, turn the manual release rod back again.

Manual release for spring loaded brake with DC solenoid Model ES(X)010A ... ES(X)250A, ZS(X)300A, ZS(X)500A

The hand release allows the manual release of the brake. By operating the manual release, the pressure plate (Pos.6) is pulled against the magnet housing (Pos.1). An air gap between the brake disc (Pos.2) and the pressure plate (Pos.6) results, the brake is open and the rotor shaft can rotate freely.



ATTENTION!

The settings of the manual release may not be changed. The manual release lever and locking arrangement are supplied separately as a by-pack kit.

Assembly of the manual release lever

Screw the manual release lever Pos. 31 and the locking arrangement Pos. 32 (if applicable) into the manual release. Insert the protective guard Pos. 33 over the lever into the fan cowl slot. If the locking arrangement is present, break out the perforation in the protective guard.

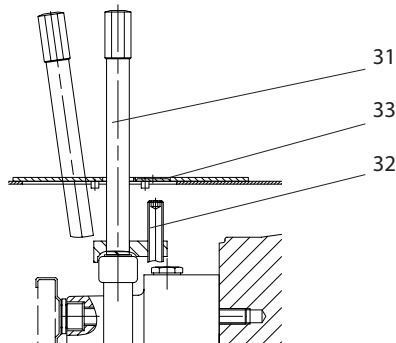

Assembly and disassembly of the manual release

The assembly of the manual release is only possible when the brake was ordered specifically for this option.

When changing the brake torque, the manual release must be re-assembled as follows:

CAUTION!

Before assembly of the manual release, the brake must be disassembled from the motor and electrically disconnected!

- Before the pressure plate is assembled, the O-Rings (Pos. 20) and the discs (Pos. 21) must be placed in the in the countersinks in the magnet housing.
- Assemble the pressure plate (Pos. 6) with the hollow bolts (Pos. 9).

CAUTION!

The hollow bolts must lie under the sealing face of the magnet housing.

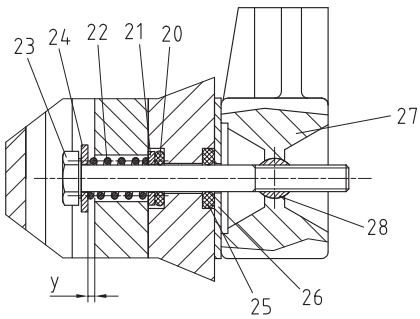
- Push the washer (Pos. 24) and then the spring (Pos.22) onto the bolt (Pos. 23). Then push all parts, from the inside looking at the sealed coil, into the bores in the pressure plate and magnet housing (Pos.1).
 - Push the O-Rings (Pos. 25) over the threads of the mounting bolts (Pos. 23) and press them into the countersink of the magnet housing (Pos. 1).
 - Push the plate (Pos. 26) over the screw thread.
 - Push the bolts (Pos. 28) into the manual release lever.
 - Screw the screw (Pos. 23) into the bolt (Pos.28).
- 
- Tighten both hexagon bolts (Pos. 23) until the pressure plate (Pos. 6) lies uniformly on the magent housing (Pos. 1).
 - Release both hexagonal bolts (Pos. 23) by X turns (see Table Setting the Manual Release). The adjusting dimension „y“ for the manual release is set this way.

Setting of the manual release



ATTENTION!:

The adjusting dimension „y“ must be set uniformly and my not be readjusted later.

- Mark the setting using locking varnish on the hand release bolts (Pos. 28).
- After assembly of the fan cowl, screw the manual release lever in the manual release and tighten.

Type	Setting the Manual Release		
	Adjusting Dimension Y [mm]	"Unsrew bolts by X turns"	Wrench size
ES(X)010	1	1,5	8
ES(X)027	1	1,5	10
ES(X)040	1	1,3	10
ES(X)070	1	1	12
ES(X)125	1,2	1,2	12
ES(X)200	1,2	1,2	12
ES(X)250	1,5	1,2	19
ZS(X)300	1,2	1,2	12
ZS(X)500	1,5	1,2	19

Locking manual release

After the manual release has been operated, this can be locked by seizing the threaded bolt against the magnet housing.

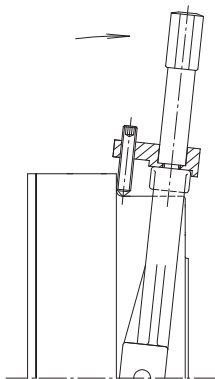

Assembly of the locking:

The existing manual release of the brakes ES(X)010 to ES(X)250 and the ZS(X)300 bis ZS(X)500 can be converted to locking manual release through assembly of the plate (Pos. 32) and the threaded bolt (Pos.33).

- Disassemble lever (Pos.31).

CAUTION!
The existing spring ring on the lever thread must be removed

- Locate plate (Pos.32) with threaded bolt (Pos.33) between the hand release and the lever.
- Tighten lever (Pos. 31)

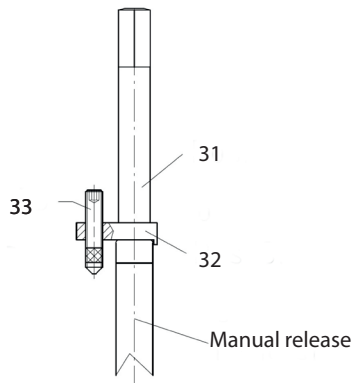

Brake	Wrench size of the threaded bolt
ES(X)010 to ES(X)027	2,5
ES(X)040	2,5
ES(X)070 to ES(X)200	4
ES(X)250	5
ZS(X)300	4
ZS(X)500	5

Gear units designed with torque arms and rubber buffers for series BF

1. Installation of the rubber buffer.

The rubber buffers provided are to be fixed in accordance with the drawings N-BF-DST, N-BK-DST or N-BS-DST and tightened to the pretension required.

2. As part of the specified maintenance intervals, the correct tensioning and conditions of the rubber buffers is to be checked and the same changed should faults be apparent. For dynamic applications, this procedure must be performed independent from the standard intervals, every 3.000 hours machine usage.

Note:

Play in the rubber buffers can result in damage to the gearwheels and bearings.

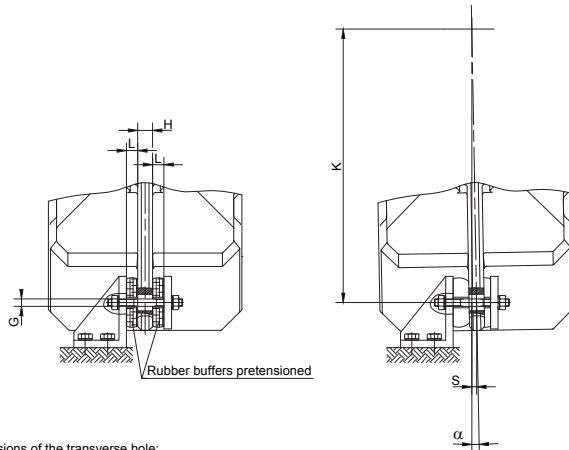

Dimensions of the transverse hole:
see dimension sheet of the respective
shaft mounted gearbox

T_2 = assigned gear torque
F = pressing force on the rubber buffers

Gear	Pos. <small>(see T22)</small>	T_2 (Nm)	K (mm)	F (N)	Pre-tensioning per rubber buffer (mm)	G	H (mm)	L (mm)	max. α (mm)	max. way s (mm)
BF06	Pos.0	95	104	913	2.0	M8	10	10	2.5°	5
BF10	Pos.1	200	155	1290	2.2	M10	16	13.5	2.5°	7
BF20	Pos.1	350	190	1842	3.0	M10	18	13	2.5°	8
BF30	Pos.2	500	210	2381	2.5	M10	18	17	2.5°	9
BF40	Pos.2	780	242	3223	4.0	M10	20	16.5	2.5°	11
BF50	Pos.3	1200	270	4444	4.0	M18	24	21.5	2.5°	12
BF60	Pos.3	2150	340	6324	4.5	M18	28	21	2.5°	15
BF70	Pos.4	5200	377	13793	4.5	M20	30	25.5	2.5°	16
BF80	Pos.5	9500	445	21348	5.5	M20	40	30	2.5°	19
BF90	Pos.5	16800	555	30270	7.0	M20	50	29.5	2.5°	24

Gear units designed with torque arms and rubber buffers for series BK

1. Installation of the rubber buffer.

The rubber buffers provided are to be fixed in accordance with the drawings N-BF-DST, N-BK-DST or N-BS-DST and tightened to the pretension required.

2. As part of the specified maintenance intervals, the correct tensioning and conditions of the rubber buffers is to be checked and the same changed should faults be apparent. For dynamic applications, this procedure must be performed independent from the standard intervals, every 3.000 hours machine usage.

Note:

Play in the rubber buffers can result in damage to the gearwheels and bearings.

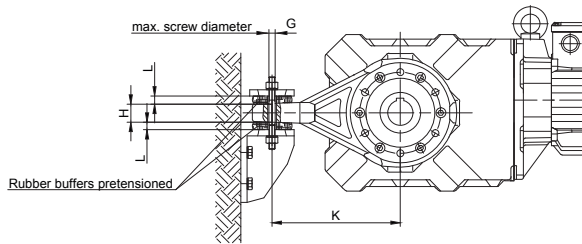

Dimensions of the transverse hole:
see dimension sheet of the respective
shaft mounted gearbox

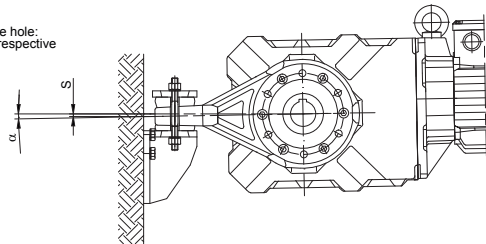

T_2 = assigned gear torque
 F = pressing force on the rubber buffers

Gear	Pos.	T_2 (Nm)	K (mm)	F (N)	Pre-tensioning per rubber buffer (mm)	G	H (mm)	L (mm)	max. α (mm)	max. way s (mm)
BK06	Pos.0	80	144	555	1.5	M8	10	10.5	2.5°	6
BK10	Pos.1	170	160	1063	1.5	M10	19	13.5	2.5°	7
BK20	Pos.1	280	180	1556	2.0	M10	19	13	2.5°	8
BK30	Pos.2	400	205	1951	3.0	M10	30	17	2.5°	9
BK40	Pos.2	680	250	2720	3.0	M10	30	17	2.5°	11
BK50	Pos.3	950	250	3800	3.5	M18	36	21.5	2.5°	11
BK60	Pos.3	2150	340	6324	4.0	M18	38	21	2.5°	15
BK70	Pos.4	5200	370	14054	4.5	M20	40	25.5	2.5°	16
BK80	Pos.5	10500	470	22340	5.0	M20	45	30	2.5°	21
BK90	Pos.5	16800	570	29474	5.5	M20	45	29.5	2.5°	25

Gear units designed with torque arms and rubber buffers for series BS

1. Installation of the rubber buffer.

The rubber buffers provided are to be fixed in accordance with the drawings N-BF-DST, N-BK-DST or N-BS-DST and tightened to the pretension required.

2. As part of the specified maintenance intervals, the correct tensioning and conditions of the rubber buffers is to be checked and the same changed should faults be apparent. For dynamic applications, this procedure must be performed independent from the standard intervals, every 3.000 hours machine usage.

Note:

Play in the rubber buffers can result in damage to the gearwheels and bearings.

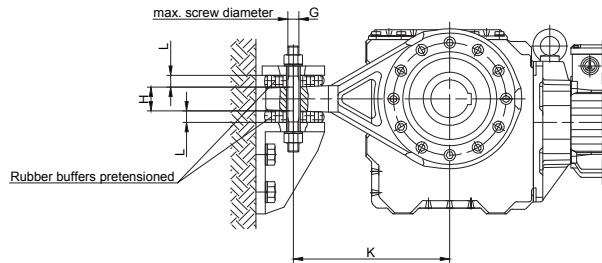

Dimensions of the transverse hole:
see dimension sheet of the respective
shaft mounted gearbox

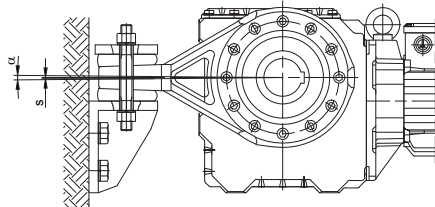

T_2 = assigned gear torque
F = pressing force on the rubber buffers

Gear	Pos.	T_2 (Nm)	K (mm)	F (N)	Pre-tensioning per rubber buffer (mm)	G	H (mm)	L (mm)	max. α (mm)	max. way s (mm)
BS03	Pos.0 <small>(see T 233)</small>	55	118	466	1.5	M8	10	10.5	2.5°	5
BS04	Pos.0	45	121	372	1.5	M8	10	10.5	2.5°	5
BS06	Pos.0	110	144	764	2.0	M10	10	10	2.5°	6
BS10	Pos.1	180	160	1125	2.0	M10	19	13	2.5°	7
BS20	Pos.2	290	205	1415	2.5	M10	30	17.5	2.5°	9
BS30	Pos.2	542	250	2096	3.0	M10	30	17	2.5°	11
BS40	Pos.3	980	340	2882	3.0	M18	38	22	2.5°	15

Geared motors with backstop

The backstop locks the geared motor in a certain direction of rotation (indication of direction with view of the mounted side of the gear unit).

Mounting

The backstop is assembled on the end shield of the motor.

The inner ring with mounted on clamping part insert is located on the extended rotor shaft. This clamping part insert consists of caging in which the individually spring-loaded clamping parts are guided. The clamping parts lay flush on the outer ring. The end guard protects against contact and the penetration of foreign objects.

Operation

When the geared motor is started, the clamping parts disengage and do not make contact until the speed of the motor drops below approximately 640/min (D..08), 740/min (D..09,D..11), 665/min (D..13 bis D..18) after disconnection or a power failure. The clamping parts then slowly rise and lock a reversing movement at the moment of rest.

The power transmission in locked state goes from the rotor shaft via the inner ring to the clamping parts and from there via the outer ring to the end shield and the housing of the geared motor.

Supply connection

The standard three phase current motors are normally connected for anti-clockwise rotation when looking at the front of the fan shaft end and with the phase sequence L1 - L2 - L3. The actual phase sequence of the mains is to be selected in such a way that the motor starts in the freewheeling direction. For the first test start, it is advisable to connect particularly larger motors in star connection to protect the backstop as far as possible.

If a brief test connection finds that the motor is not connected in direction of rotation, but in the blocked direction, two mains leads are to be exchanged as with any normal change of direction of rotation. After a wrong connection, check fuses and motor protection switches and check for correct terminal board connection as indicated on the rating plate.



Safety information:

Mounting, connection, adjusting and maintenance work may only be carried out taking into account the safety information given on the accompanying information sheet No. 122 and of the operating instructions for the backstop.

Assembly of the freewheeling mechanisms may only be carried out by trained specialist personnel taking into account the installation information!

The machinery must be secured against rollback before work is performed on the backstop!

Assembly of standard motor with C-Adapter (IEC and NEMA)

Safety Information

Connection and maintenance work may only be carried out taking into account the safety information on pages 3/4.

Motor Attachment

The assembly of standard motors in the size range IEC 56 to IEC 280 and NEMA 56C to NEMA 405TC using the C-Adapter is to be performed according to the following plan:

- I. Remove assembly plug 1
- II. Arrange the clamping ring so that the clamping screw 2 is under the assembly hole. Loosen the clamping screw 2 so much that the clamping ring 4 does not tighten on the intermediate shaft 3 anymore.
- III. Arrange the motor and rotor shaft to the gear side mounting face
- IV. To make assembly easier, bring the motor and gearbox together in the vertical position (motor pointing upwards)
- V. Insert motor shaft into the intermediate shaft without forcing
- VI. Tighten clamping screw 2
- VII. Tighten motor fitting screws 5
- VIII. Insert assembly plug 1

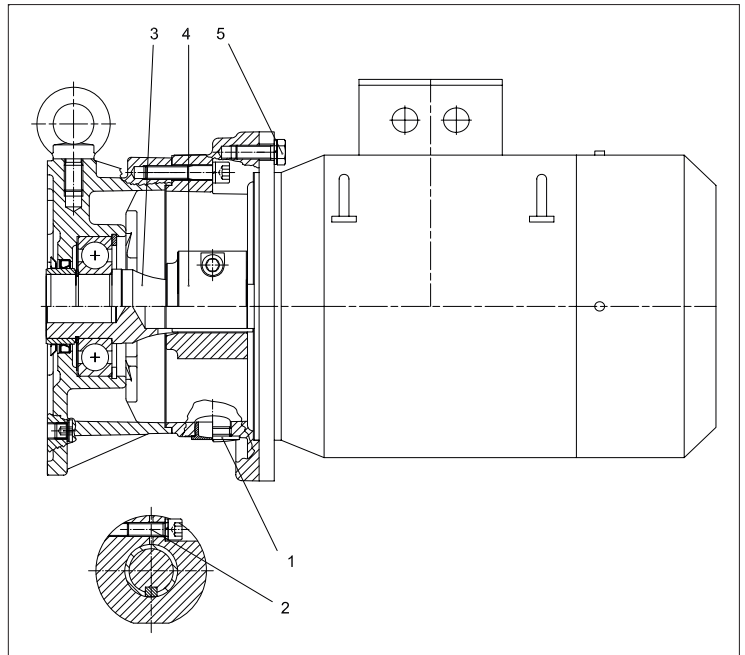

Assembly and disassembly of the shrink-disc

The shrink-disc is supplied ready to be installed and should therefore not be dismantled. The shrink-disc may not be clamped without fitting the shaft.

The shaft must be fitted or the hub pushed onto the shaft in the area of the shrink-disc seat.

The tightening bolts must then be tightened evenly around the circumference until the front side face of the outer ring and inner rings is flush. The state of clamping can thus be monitored visually.

To disassemble, loosen all screws evenly in sequence. If the outer ring does not automatically separate from the inner ring, a number of tightening bolts may be removed and screwed into the neighbouring forcing-off threads.

Any rust on the shaft in front of the hub must be removed before the shaft is removed or the hub is taken from the shaft.

Removed shrink-discs only need to be dismantled, cleaned, and regreased before refitting if they are very dirty. In this event, a solid lubricant with a coefficient of friction of $\mu = 0.04$ or better is to be used.

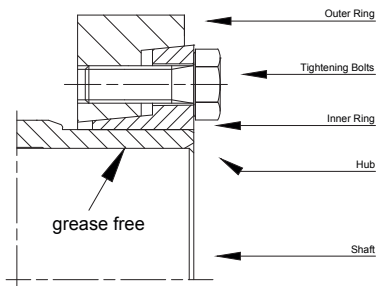

Information on the storage of geared motors with cage rotors

If geared motors are to be stored for an extended time before start-up, increased protection against damage by corrosion or humidity can be achieved by observing the following information. Since the actual loading depends very strongly on local conditions, the time data can be regarded only as a guide value. It should also be noted that this data does not include any extension of the warranty term. If disassembly is necessary before start-up according to this information, it is recommended that the nearest BAUER franchised workshop or representatives be called in. The instructions contained in the after-sales manual are to be observed in all cases.

Geared motor condition and storage space

The plugs supplied by the works in all entry holes on the terminal box are to be checked for damage caused during transportation and for correct positioning and replaced if necessary.

Any vent valves which are present are to be removed and replaced with a suitable cover screw for the length of storage.

Any damage caused during transit to the exterior paint layer or to the rust protection of the bright metal shafts, including hollow shafts, must be repaired.

The storage space should be dry, well-ventilated and vibration-free. If the temperature in the space exceeds the normal range of approximately -20°C to $+40^{\circ}\text{C}$ for an extended period of time or varies strongly frequently, it could even become necessary to employ the measures before start-up specified in section 3 after shorter storage times.

Measures during the storage period

Space permitting, it is recommended that the drive units be turned 180° after approximately one year and annually thereafter so that the lubricant in the gear unit covers the bearings and gearwheels which have previously been positioned on top. Also, the output shaft should be turned manually in order to churn the rolling-contact bearing grease and distribute it evenly.

Turning the drive unit does not have to be carried out if the gear unit enclosure is completely filled with lubricant as the result of a special agreement. In this case, the lubricant level before start-up is to be reduced to the desired value as defined in the operating instructions and the lubrication information plate.

Measures before start-up

Motor component

- Insulation measurement
Measure the insulation resistance of the winding with commercially available measuring apparatus (e.g. with a magneto) between all winding parts and between the winding and the enclosure.

- Measured value above 50 megohm: no drying necessary, new condition
Measured value under 5 megohm: drying advised
Measured value approximately 1 megohm: lowest permissible threshold
- Drying the winding by standstill stator heating without disassembly
Connection to stepless or tapped variable alternating current voltage up to approximately 20% maximum of the rated voltage. Heating current max. 65% of the rated current according to the rating plate. Observe heating up for first 2 to 5 hours; reduce heating voltage if necessary. Heating duration approximately 12 to 24 hours until insulation resistance rises to desired value.
- Dry the winding in the oven after disassembly
Dismantle the motor in the appropriate manner
Dry the stator winding in a well ventilated drying oven at between 80° C and 100° C for approximately 12 to 24 hours until the insulation resistance rises to the desired value.
- Lubricating the rotor position
If the storage period exceeds approximately 2 to 3 years, or the temperatures were very unfavourable throughout a shorter storage period as described in "Geared motors with three phase cage rotors" paragraph 3, the lubricant in the rotor positions must be checked and refilled if necessary. For checking, a partial assembly on the fan side is sufficient, where the rolling contact bearing becomes visible after removal of the fan cowl, fan and bearing flange (end shield).

Gear unit component

- Lubricant
If the storage period exceeds approximately 2 to 3 years, or the temperatures were very unfavourable throughout a shorter storage period as described in "Geared motors with three phase cage rotors" paragraph 3, the lubricant in the gear unit must be changed. For detailed instructions and lubricant recommendations please see chapter lubrication quantity.
- Shaft seals
When changing the lubricant, the function of the shaft seals between the motor and gear unit as well as on the output shaft must also be checked. If a change in shape, colour, hardness or sealing effect is determined, the shaft seals must be replaced appropriately under observance of the after-sales manual.
- Gaskets
If lubricant is draining out at the connecting points on the gear unit enclosure, the sealing compound must be replaced as described in the after-sales manual.
- Vent valve
If a vent valve was replaced with a cover screw when storing, the vent valve must be refitted to the point of removal.

Notes

